



## **New Zealand Telecommunications Forum**

# **TCF Premises Wiring Cable Installers Guidelines for Telecommunication Services**

<b>Code Status:</b>	<b>Approved</b>
<b>Code Classification:</b>	Guidelines
<b>Date:</b>	September 2021
<b>Version:</b>	7.0

"© 2021 The New Zealand Telecommunications Forum Inc. Except as provided by the Copyright Act 1994, no part of this material may be reproduced or stored in a retrieval system in any form or by any means without the prior written permission of the New Zealand Telecommunications Forum Inc."

## Executive Summary

### General

This Guideline was prepared by the TCF Premises Wiring Working Party (Working Party) and is a revision of the TCF Premises Wiring Guidelines for Cable Installers (2015). This Guideline is a result of consensus among representatives of the Working Party: 2degrees, Chorus, Enable Networks, Northpower Fibre, Spark, Ultrafast Fibre, Vodafone.

This Guideline supports the recommendations of the Australia and New Zealand Standard for generic cabling for homes (AS/NZS 11801.1:2019). It also sets out the functional specifications for the provision of Generic Cabling to support Telecommunications Services in New Zealand Residential, SDU and MDU premises.

### Purpose:

The Guideline outlines the Telecommunications industry's recommendations regarding the provision of Generic Cabling in residential, SDU and MDU premises to Interested Parties.

### Anticipated benefits for Consumers

To define a set of recommendations which will provide good long-term performance and reliability of Telecommunication Services for the New Zealand consumer. A Generic Cabling system will provide an open, flexible platform designed to work today and in the future with a range of access technologies including fibre, cable, copper, fixed wireless, and satellite broadband, meaning the customer has flexibility on what type of broadband service they purchase from a Retail Service Provider. And they can switch at any time.

### Anticipated benefits for Industry

Provides guidance to Interested Parties involved in Generic Cabling installations for voice and broadband telecommunications services to ensure good performance and reliability of Telecommunications Services within a residential, SDU and MDU premises. The guidelines will also inform cable installers on the principles and practices for planning, installing, and maintaining a generic cabling system.

### Guideline Revision

This is the second iteration of this Guideline. The following is a high-level overview of the revisions:

- All diagrams and tables have been updated:
- Section C:
  - o Recommendations expanded for both wired and wireless connectivity to facilitate the wider range of devices connecting to telecommunications services with the premises. These devices are brought together via a general purpose or "generic" cabling system which in turns supports Wi-Fi connectivity for those devices not plugged in;
  - o Included new recommendations outlining three levels of home wiring – a minimum standard to which all new houses should conform, an acceptable standard which reflects industry best practice, and an advanced standard which covers of current and future smart home componentry including automation etc.
- Section E:
  - o Expanded the scope to include recommendations for cable, fixed wireless and satellite technologies;
- Section G:
  - o Updated relevant industry standards;
- Section H:

- Revised definitions and terms;
- Section I:
  - Included minimum premises home wiring requirements that will meet the Governments Digital Inclusion vision, with future proofing for integrated Wi-Fi if required;
- Section J:
  - Updated information on the installation and location of Customer Premises Equipment (CPE)
- Section K:
  - Updated recommendations for the installation of fibre pathways within the premises;
  - Updated installation recommendations for the External Termination Point (ETP);
- Section L:
  - Installation Guidelines to align with current industry practice.

## Compliance

TCF Guidelines are documents with which compliance is voluntary. They cover a range of industry topics including consumer, operational and technical matters. They set out minimum recommendations and specifications for the telecommunications industry and any interested parties to follow particularly when meeting a good building standard and home wiring components of a new build.

VERSION	DATE	AUTHOR	COMMENTS
2.2	February 2010	TCF	Endorsed by the TCF Board.
4.0	31 May 2011	TCF	Approved
5.0	September 2015	TCF	Approved by the TCF Board
5.1	July 2020	Chorus	Draft proposed changes for LFC comment/feedback
5.2	October 2020	TCF	Working Group feedback incorporated
5.3	November 2020	TCF	2nd round of Working Group feedback incorporated
5.4	December 2020	TCF	3rd round of Working Group feedback incorporated
5.5	February 2021	TCF	Final comments from Working Group incorporated
5.6	April 2021	TCF	Circulated for Working Party approval for public consultation
5.7	May 2021	TCF	Approved by Working Party for Public Consultation
6.0	June 2021	TCF	Board approved for public consultation
6.1	August 2021	TCF	Approved by Working Party for final Board Approval
7.0	September 2021	TCF	Approved by the TCF Board

## Contents

A.	INTRODUCTION.....	7
B.	APPLICABILITY.....	7
C.	OVERVIEW.....	7
D.	PURPOSE AND OBJECTIVES.....	9
18.	Purpose.....	9
19.	Objectives.....	10
E.	SCOPE.....	10
20.	Scope.....	10
21.	Exclusions from Scope.....	11
F.	COMPLIANCE.....	11
G.	INDUSTRY STANDARDS.....	11
H.	DEFINED TERMS.....	12
I.	SYSTEM DESIGN RECOMMENDATIONS.....	17
25.	System Objectives.....	17
J.	GUIDELINES/CONSIDERATIONS.....	19
26.	ONT Location.....	19
27.	RGW Location.....	19
28.	TV Guidelines.....	19
K.	SYSTEM DESIGN DETAILS.....	19
29.	System objectives.....	19
30.	Wiring Architecture.....	20
31.	Fibre pathways (ducts or microducts).....	21
32.	Alternative to fibre pathways.....	21
33.	Low Smoke Zero Halogen (LSZH) internal Duct Routes.....	21
34.	Generic Cabling System Components.....	22
35.	Major System Components.....	23
36.	Underground service lead-in cables or pipe.....	24
37.	External Termination Point (ETP).....	25
38.	ETP Location.....	25
39.	Demarcation Point.....	26
40.	Special Cases.....	27
41.	Multi Dwelling Unit (MDU).....	27
45.	MDU Generic Cabling.....	28
46.	MDU Cable Ownership:.....	28
47.	Home Distributor (SDU and MDU).....	29
48.	Home Distributor Location.....	29
49.	Generic Cabling termination hardware within the Home Distributor.....	31

50.	Hardware for other services within the Home Distributor .....	32
51.	Power Supply.....	32
52.	Generic Cabling .....	32
53.	Performance characteristics of TP cabling.....	33
54.	Internal Generic Cabling.....	33
55.	Ducting and microducts .....	34
56.	Telecommunications Outlet (TO).....	35
L.	INSTALLATION GUIDELINES .....	36
60.	Safety Requirements.....	37
61.	Telecommunication Wiring Practices.....	37
62.	Cross-connections and Commoning of TO's for traditional analogue Telephone service .....	42
63.	Connection of Broadband services.....	42
64.	Mounting Hardware.....	43
65.	Faceplates and socket orientation .....	43
66.	Copper Cable termination .....	43
67.	Fibre Termination.....	44
68.	Wire mapping.....	44
69.	CPE Connection to Copper Wire Network/Service Provider lines.....	45
70.	Earthing .....	46
71.	Earthquake Protection .....	46
M.	INSTALLATION TESTING .....	46
74.	Cable Installer's obligations.....	46
75.	Damage .....	46
76.	Visual Inspection .....	47
77.	Verification .....	47
78.	Qualification Testing .....	49
79.	Qualification Test Instruments.....	49
N.	RECORDS MANAGEMENT .....	51
80.	Generic Cabling Management.....	51
81.	Installation records.....	52
82.	Compliance Statement Documentation.....	52
83.	Special Situations .....	52
O.	APPENDIX.....	53
84.	Interim Steps for Legacy Wiring and DSL interference .....	53
85.	Testing for DSL leakage to AM radio .....	53
86.	New Home Schematic Diagrams .....	54
87.	Connection Type .....	54
88.	RGW/Modem Locations .....	57

89.	Broadband distribution scenarios .....	58
90.	Voice distribution scenarios .....	61

## A. INTRODUCTION

1. The New Zealand Telecommunications Forum (“TCF”) established the Premises Wiring Working Party to provide recommendations on the provision and maintenance of Premises Wiring in residential, Single Dwelling Unit (SDU) and Multi-Dwelling Unit (MDU) premises in New Zealand to support telecommunication services, offered over fibre, copper, cable, fixed wireless and satellite technologies.
  2. Recent developments in technologies and services, and the Governments Ultra-fast Broadband initiative now require extensive wiring and cross-connect facilities to be an essential part of the modern home.
  3. The purpose for these recommendations is to inform cable installers on the principles and practices for planning, installing, and maintaining a Generic Cabling system to provide an open, flexible platform for current and future telecommunication services within the premises.
  4. It is recommended that developers of Greenfields developments, either subdivisions or MDUs (residential or commercial premises) should contact the Access Network Provider at the preliminary stage of their planning to ensure that the correct capacity is provided to meet telecommunication requirements.
- 

## B. APPLICABILITY

5. This document is applicable to all residential, SDU and MDUs being constructed and undergoing major renovations. It is designed to work today and in the future with a range of access technologies including fibre, cable, copper, fixed wireless, and satellite broadband, meaning the customer has flexibility on what type of broadband service they purchase from a Retail Service Provider. And they can switch at any time.
- 

## C. OVERVIEW

6. There is a clear trend towards increasing levels of integration between the various services and applications in the home. Connectivity in years gone by was based on just telephony and progressively some data. Today connectivity needs to facilitate multiple devices including (but not limited to):
  - 6.1. Computers and laptops
  - 6.2. Mobile phones and tablets
  - 6.3. E-readers
  - 6.4. Smartwatches and GPS devices
  - 6.5. Household appliances: fridges, heat pumps, washing machines, vacuum cleaners etc
  - 6.6. Virtual assistants such as Amazon Alexa, Google Home and other smart speakers
  - 6.7. Monitoring systems: security systems, baby monitors etc
  - 6.8. Gaming consoles, VR
  - 6.9. Attached to house 'smarts': locks, lights, alarms, solar, weather monitoring, automated curtains/blinds
7. These devices are brought together via a general purpose or “generic” cabling system which in turns supports Wi-Fi connectivity for those devices not plugged in.
8. The development of the “2-wire” telephone wiring code of practice in 1990s led to the widespread use of 2-pair telecommunications cable in most homes and small businesses. That code has proved satisfactory for supporting current telecommunications services, including telephone and copper broadband delivery.
9. Copper broadband services use the same frequency band as radio broadcasting, so under certain circumstances each may interfere with each other. Normally DSL is carried by wire whereas radio reception is by radio waves traveling through space. If “2-wire” or “3-wire” telephone wiring is used there is a high chance that the DSL signal

will be radiated from the cable and cause interference to AM radio reception. If properly terminated Unshielded Twisted Pair (UTP) is used, as outlined in this Document, then telecommunication services stay within the UTP cable and do not cause interference to radio.

10. However, fibre optic network services as well as in-home network (LAN) and entertainment applications require a level of functionality and performance that traditional residential, SDU and MDU premises wiring cannot provide. Broadband connection speeds of up to 10 Gbps are now on offer, and devices capable of utilising these speeds will be available in the very near future. This further exacerbates the digital divide between premises with and without network cabling.
11. Although higher performing business grade wiring systems, typically Unshielded Twisted Pair (UTP) Cat5 and above, have been used in many new homes and offices for some years, most homes have continued to install the much lower performing 2-wire system for telecommunications-based services. That choice of cabling structure will limit the ability of those occupying the home to access and enjoy future network as well as in-home entertainment and control applications.
12. Other networking technologies, such as Wi-Fi and associated Mesh systems are becoming more prevalent, and are often useful extensions of wired networks. Most common home networking is likely to be a combination of wired and wireless connectivity, with wired providing reliability and performance, and wireless providing flexibility and mobility within the home. In particular, wired is best for fixed locations in the premise, including providing reliable, high performing connectivity to wireless access points. Wi-Fi performance impairments include:
  - 12.1. Distance - The closer you are to the wireless access point, the better it will perform. Wireless connectivity (Wi-Fi) has a limited range and can only reach so far. Other devices, household appliances and physical obstructions can also reduce Wi-Fi range.
  - 12.2. Number of users - The more users connected to your Wi-Fi, the less wireless bandwidth there is available to each device. This can cause your Wi-Fi to slow down (even if you are connected to Fibre).
  - 12.3. Interference - There are many things that can interfere with the quality of your Wi-Fi signal. Appliances like microwave ovens, cordless phones, Bluetooth speakers and baby monitors make it difficult for signal to pass by. Other obstacles like hot water cylinders, wooden and concrete walls, and anything with metal in it will also get in the way.
  - 12.4. Other access points - Neighbours Wi-Fi is a common cause of signal interference, especially if you live in an apartment with lots of other Wi-Fi access point around. As you move around your home, interference can make it difficult to get strong and smooth wireless signal.
  - 12.5. Device - A recent, name-brand modem or access point is more likely to outperform a no-name branded one. It's best to use a modern device which uses the latest Wi-Fi technology. Older modems and access points can limit the speed and quality of wireless signal.
  - 12.6. Position - It is best to have your router or access points placed up high and centralised or evenly dispersed in the home.
  - 12.7. Mesh - A wireless mesh network is a communications network made up of radio nodes organised in a mesh topology. Wi-Fi devices connect to the nearest node. The nodes interconnect to send and receive data.

**Note:** This document does not cover Wi-Fi network design and installation. If you are not sure what you need, consult an independent specialist.
13. Structured cabling is an enabler. Below are the top considerations when wiring for a new home or completing a major renovation:
  - 13.1. Flexibility – allows the homeowner to change retail provider and/or access technology with the minimum of disruption.
  - 13.2. Speed – with speeds of 10Gbps now in the market, the best way to use this speed is with suitable ethernet cabling connecting active equipment.
  - 13.3. Reliability – essentially, if you have power, then your wired network is 'always on'.



- 13.4. Reduced congestion – Multiple devices are not competing for the same wireless frequencies when they are hard wired.
  - 13.5. Not all devices are mobile, so not all devices need operate wirelessly. Wiring stationery devices frees up bandwidth for mobile devices.
  - 13.6. Future proof – allowing rapid technological changes in future smart home technologies to be more easily integrated. For example:
    - 13.6.1. Home networking
    - 13.6.2. 3D and web enabled televisions and projectors
    - 13.6.3. Energy management
    - 13.6.4. Videoconferencing
    - 13.6.5. Security
    - 13.6.6. Connected appliances
  - 13.7. Scale – allows more devices to be added in the future.
  - 13.8. Long life – physical cabling does not typically degrade and will likely last the life of the house.
  14. Physical cabling supports in-home Wi-Fi coverage. By cabling from the modem or router to the Wi-Fi access points throughout the house, Wi-Fi will simply work better with less conflicts.
  15. By providing for future connectivity in the home, structured cabling and fibre pathways will cater for both current and future connectivity requirements. The most cost-effective time to install this in a home is at new build time.
  16. This document will outline three levels of home wiring – a minimum standard to which all new houses should conform, an acceptable standard which reflects industry best practice, and an advanced standard which covers of current and future smart home componentry including automation etc.
  17. Why use structured cabling?
    - 17.1. You don't know what you don't know. How you live in your house today may not be how you live in it in the future. You may choose to install new technology in the future which requires connectivity.
    - 17.2. Moves, changes, rearrangements, and upgrades can be performed easily with preinstalled structured cabling. Retrofitting structured cabling in an already built house is invasive, costly, and messy.
    - 17.3. Structured cabling will add value and appeal to potential future purchasers of your house.
- 

## D. PURPOSE AND OBJECTIVES

### 18. Purpose

- 18.1. The purpose of this document is to outline the Telecommunications Industry's recommendations regarding the provision of Generic Cabling in residential, SDU and MDU premises to Interested Parties and to define a set of recommendations which will provide good long-term performance and reliability of Telecommunication Services for the New Zealand consumer. This is about providing a premises communications infrastructure platform, the elements of which provide device connectivity.
- 18.2. This document deals with requirements for direct connection to Service and Access Network Providers networks.
- 18.3. This document is intended for use by Interested Parties involved in Generic Cabling installations for Telecommunications Services namely:
  - 18.3.1. Consumers. Including building owners;

- 18.3.2. Building industry providers (architects, builders, developers, etc.);
- 18.3.3. Suppliers of technology (electrical contractors, equipment suppliers, etc.);
- 18.3.4. Retail Service Providers; and
- 18.3.5. Access Network Providers.

## 19. Objectives

- 19.1. The objectives of this document are to define a set of recommendations which will provide good long-term performance and reliability for the New Zealand consumer by:
  - 19.2. Recommending minimum requirements regarding the provision of Generic Cabling to support Telecommunications Services in residential, SDU and MDU premises in New Zealand.
  - 19.3. Setting out best practice management principles that parties involved in the design, installation and maintenance of Generic Cabling and facilities should:
    - 19.3.1. Identifying the rights and responsibilities of Interested Parties,
    - 19.3.2. Providing guidelines to providers of Generic Cabling to assist them to comply with their legal obligations and with this document,
    - 19.3.3. Carry out adequate testing of the Generic Cable installation to ensure that it is working, and complete adequate documentation of the testing,
    - 19.3.4. Achieving a balance between industry and End-User interests,
    - 19.3.5. Promoting the informed, fair, and safe use of Generic Cabling; and
    - 19.3.6. Being technology neutral.

## E. SCOPE

### 20. Scope

20.1. This document addresses requirements for the support voice and broadband Telecommunication Services that a Retail Service Provider may deliver over copper, fibre, cable, fixed wireless and satellite connections to SDU and MDU premises, as illustrated in Figure 1 below. In the case of SDU's also include the requirement for an ETP.

**Figure 1: Scope of Premises Wiring**

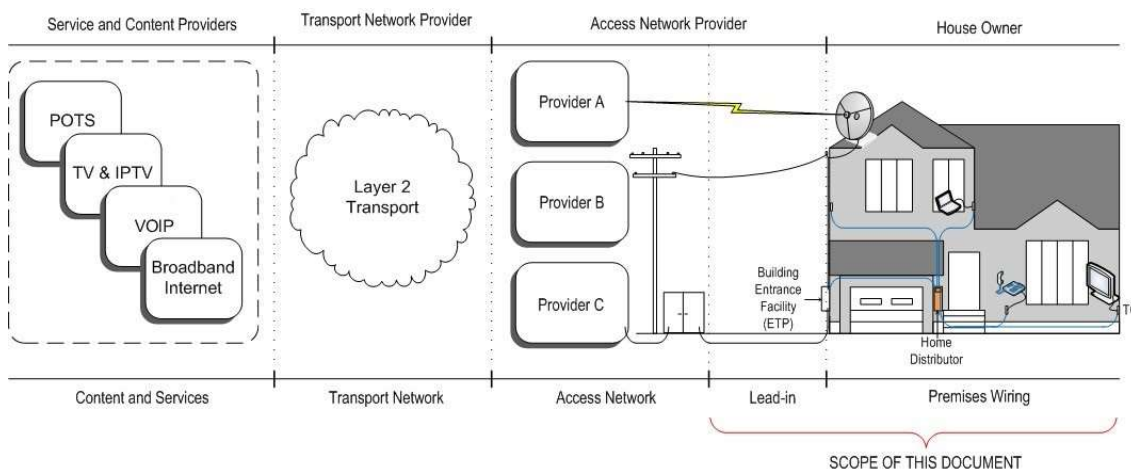

- 20.2. This document specifies Generic Cabling as defined by AS/NZS 11801.1:2019: for Information and Communications (Telecommunications) Technologies (ICT).
- 20.3. The document specifies Generic Cabling that comprises one or more of the following:
- 20.3.1. Twisted pair (TP) copper cabling; and
  - 20.3.2. Fibre optic cabling.
- 20.4. This document does not cover extensive installation of coaxial cabling (RG 6). Some homeowners may choose to use coaxial cable for analogue/digital TV. Coaxial is only worth installing if the homeowner intends to use it. Coaxial cabling from a Free-to-air TV aerial and/or satellite dish position to any TV or set top box position will suffice for almost all new houses. A smart TV may provide everything the Homeowner needs without the additional cost of installing coaxial cable. Reference AS/NZS 1367:2016 for distribution of digital television, radio, and in-house analogue television.
- 20.5. The Generic Cabling practices and recommendations detailed in this document can also apply to commercial or business premises where Generic Cabling systems are appropriately utilised.
- 20.6. Some technologies like Fixed Wireless Access do not require a lead in connection but can still be connected directly into the premises wiring. However, a duct should always be installed to give the owner/occupier the option of connecting to a fibre or copper network.

## 21. Exclusions from Scope

- 21.1. The following items are excluded from the scope of this document, but are potential options when considering in-home cabling:
- 21.1.1. Electrical Wiring and in-home power line carrier technology including ethernet over power;
  - 21.1.2. Customer Premises Equipment (CPE);
  - 21.1.3. Home automation, security systems, and entertainment systems and control applications within residential, SDU and MDU premises; and
  - 21.1.4. Special purpose cable types for control systems for lighting, heating control, TV (coaxial), entertainment and security.

---

## F. COMPLIANCE

22. This document outlines the Telecommunications Industry's recommendations for the design, installation and maintenance of Generic Cabling at a Residential, SDU and MDU premises to support telecommunication services over fibre and copper lines.
23. Any Generic Cabling installations for Residential, SDU and MDU premises should comply with the relevant industry standards, legislation or Commerce Commission determinations and their subsequent revisions.

---

## G. INDUSTRY STANDARDS

24. This document supports the recommendations of the Australia and New Zealand Standard for generic cabling for homes (AS/NZS 11801.1:2019) and for Coaxial and Fibre-Optic distribution of Analog and Digital Television and Sound Signals in Single and Multiple Dwellings (AS/NZS 1367). It also sets out the functional specifications for the provision of Generic Cabling to support Telecommunications Services in New Zealand Residential, SDU and MDU premises.

Title	Description
AS/NZS 3000:2018	Electrical Installations
AS/NZS 11801.1:2019	2019 Information technology - Generic cabling for customer premises <b>Note:</b> AS/NZS 11801.1:2019 Information technology - Generic cabling for customer premises is part 1 of 6 parts. Only part 1 has been adopted by New Zealand. Parts 2-6 are AS standards only, but some/all are still applicable: <ul style="list-style-type: none"> <li>• Part 2: Office premises</li> <li>• Part 3: Industrial premises</li> <li>• Part 4: Single-tenant homes</li> <li>• Part 5: Data centers</li> <li>• Part 6: Distributed building services</li> </ul> Supersedes: <ul style="list-style-type: none"> <li>• AS/NZS 3080:2013</li> <li>• AS/NZS ISO/IEC 15018:2005</li> <li>• AS/NZS ISO/IEC 24702:2007</li> </ul>
AS/NZS 3084:2017	Telecommunications installations - Telecommunications pathways and spaces for commercial buildings
AS/NZS 3085:2004 (Reconfirmed 2016)	Telecommunications installations - Basic requirements
AS/NZS 3112:2017	Approval and test specification - Plugs and socket-outlets
IEEE 802.3 2018	Power over Ethernet
Fair Trading Act 1986	
Consumer Guarantees Act 1993	

## H. DEFINED TERMS

In this Document, unless the context otherwise requires:

**Access Network Provider (ANP)** means the Party to whose network the end customer is connected and over which services are supplied. The network connection can be supplied over any of fibre, copper, cable, fixed wireless or satellite technologies. Note that an ANP may also be an Access Service Wholesaler and/or a Retail Service Provider.

**APC** refers to Angle Polished Connector.

**Balanced Pair Cable** is a cable consisting of one or more metallic symmetrical cable elements (twisted pairs or quads) also known as Cat5e and above, as referenced in the ISO/IEC 11801.

**BICSI (Building Industry Consulting Services, International)** is an association that promotes data cabling standards.

**Broadband** means wide bandwidth data transmission which transports multiple signals and traffic types. Broadband is typically referred to as “Data” throughout this document.

**BT jackpoint** means any jackpoint which mates with a plug to BS 6312 standard.

**Category (Cat)** refers to the rated design performance of a particular cable.

**Cross-connection** is any arrangement which enables a jackpoint to be associated with a specific service.

**Commoning** means being a facility to wire multiple phone ports in parallel.

**Customer premises equipment (CPE)** is any telecommunications terminal equipment connected to the customer’s wiring, other than CLNE.

**Customer** means a person who has a bona fide Billing Relationship with a Service Provider in respect of a Telecommunication and/or Broadcast Service. The Customer is the end user (i.e., not a wholesale customer).

**Customer-located network equipment (CLNE)** means access network provider / service provider network terminating equipment required to provide a specific service and located within the customer's premises on the customer's side of the network demarcation point.

**Daisy-chain (or loop) wiring** means a previously common form of wiring where a cable to one jackpoint is connected to another cable to the next jackpoint.

**Data** means transmission of signals constituting traffic. Data is typically referring to "Broadband" throughout this document.

**Demarcation point** is the copper network demarcation point is the point at which the service lead-in cable enters the customer's building and, usually, also the point at which the customer's wiring is connected to the network service lead-in cable. The fibre demarcation point is the port on the ANP network equipment (CLNE) which delivers the service. Typically, this is the Ethernet port on the ONT.

- To avoid any doubt, the service delivery point is on the customer side of the CLNE.

**Digital Subscriber Line (DSL)** is a generic term for broadband delivered over copper.

**EMI** means Electromagnetic Interference, also called radio-frequency interference (RFI) when in the radio frequency spectrum, is a disturbance generated by an external source that affects an electrical or data circuit.

**External cable** is a cable intended for installation outside buildings, exposed to the weather or ground contact, and provided with an appropriate protective sheath.

**External Termination Point (ETP)** means an external box, in which the service lead-in cable is connected to the internal building wiring. It is also (incorrectly) known as External Test Point, the Network Termination Device or demarcation point, when provided.

**Fibre** a thin, flexible, transparent fibre that acts as a waveguide, or "light pipe", to transmit light between the two ends of the fibre. It is typically made from glass. Two standards are used when specifying fibre: ITU-T G.657 (bend insensitive) and ITU-T G.652.

**Fixed Wireless Access** is a service which provides voice and broadband services over a mobile network. This technology does not require a physical lead in connection. It still uses the in-home premises wiring to distribute broadband and/or voice services. The service is provided using a wireless modem with a small built-in antenna. An external antenna can be used to improve performance if needed in some locations.

**Generic cabling** is often referred to as "structured cabling", a cabling system capable of supporting a wide range of ICT and BCT services which is installed without detailed knowledge of the required applications. As referred to 11801.1:2019 AS/NZS 11801.1.

**Hardware (or line hardware)** refers to any fixed wired device other than CPE. All hardware attached to the ANP network must comply with the Electrical (Safety) Regulations 2010, as outlined in Schedule 4. Where a specific standard is not available, then AS/NZ 3820 - Essential Safety Requirements for Electrical Equipment from Schedule 2 of the Regulations, may be applied.

**Home Distributor** is the central point of a generic cabling system, consisting of a cabinet or cupboard housing cross-connection and test facilities for the premises cabling and associated services. Also called a Home Distribution Box, Home Distribution Hub or Star Wiring Box.

**Insulation Displacement Connector (IDC)** is commonly used to terminate (punch down) wiring at hardware.

**Inside cable** is a telecommunications cable intended only for use within a building.

**Interested Parties** includes the following: Architects, Specifiers, Installers, Cablers, Security System providers, and Home Automation specialists, Electrical Contractors, Builders, Consumers, Developers, Equipment Suppliers and Service Providers.

**ITU-T G.hn** is a standard promoted by the HomeGrid Forum that allows existing power, telephony and coaxial wiring to be used for providing Ethernet services.

**Jackpoint** is any type of outlet used for plug-connecting CPE.

**Jumper** refers to a hard-wired cross-connection (not using plugs and sockets).

**Keystone** module is an industry standard type of telecommunications outlet used in residential and business environments. The systems consist of a modular faceplate to which outlets are mounted.

**Lead-in cable** is a term used for infrastructure installed on private property that serves one or multiple customers. In this document, the term 'Service Lead-in' has been used throughout this document.

**Lead-in Duct (LID)** is a duct installed from the property boundary or a network terminal to the customer's premise.

**Line grabbing** is a function of series connected CPE which disconnects other wiring and CPE from the line to either terminate or initiate a call on a voice line.

- Examples are medical and security alarms programmed to call a pre-determined number when triggered independent of whether the line is already in use.

**Low Voltage (LV)** is any voltage exceeding 42.4 V peak AC or 60 V DC, but not exceeding 1000 V peak AC or 1500 V DC. 230 V wiring is defined as Low Voltage and must be segregated from telecommunications wiring.

**Mesh** systems consist of a main router that connects directly to the modem, and one or more satellite modules, or nodes, placed around the premises for full WiFi coverage. WiFi devices are moving off proprietary Mesh systems toward a common standard – EasyMesh – which will allow devices from different manufacturers to talk to one another.

**Multi-dwelling Unit (MDU)** includes semi-detached, apartments, townhouses, gated communities and assisted-living facilities that share a common property boundary. MDU facilities may be under a single roof or they may consist of multiple buildings on a residential campus. MDUs may include only residential units or they may have residential units along with commercial and retail spaces. The BICSI defines 3 types of MDUs<sup>1</sup>:

- (a) Low-rise MDUs: Each unit has access to the ground level and also has a roof line such as townhouses and semi-detached dwellings.
- (b) Mid-rise MDUs: These include duplexes, two storey apartments and other building styles in which units are stacked upon one another.
- (c) High-rise MDUs: High-rise MDUs most closely resemble large commercial buildings with few units having direct access to the roof line or ground floor.

**Must** refers to matters which are essential for compliance with the Document.

**Network lateral** is network allocated to an individual customer or to a network access terminal on private property. It is a short extension of the communal network from the road reserve to the customer boundary.

**Network Operator** means the same as a Regulated Fibre Service Provider as defined in Part 1 s 5 of the Act and may also be referred to as a Local Fibre Company. Including their sub-contractors acting on their behalf.

**New Zealand Telecommunications Forum or "TCF"** means the New Zealand Telecommunications Forum Incorporated Society of New Zealand.

**Optical Network Termination (ONT)** is a unit provided by the access network provider at the point of termination of its optical fibre lead-in cable to facilitate fibre broadband and voice services.

**Note:** An ONT is a permanent fixture in the premises, and as such should be installed in a location which means it is less likely to be inadvertently removed. A plastic Home Distribution Box is an ideal location.

---

<sup>1</sup> Excerpt from 'Residential Network Cabling' by BICSI, ISBN-13: 978-0071382113

**Pair** any set of two wires, which are usually twisted in a cable, used to provide a circuit.

**Party** means a Person bound by this Document under the Telecommunications Act or a Person signed up to this Document.

**Patch cord** a means of cross-connection using plug-ended cords between the socket terminating the associated jackpoint cable and the socket used for the service being connected.

**Person** means a legal person and includes a company and any other legal entity.

**POE** stands for "Power over Ethernet." PoE provides electrical current over an Ethernet connection. It powers electronic devices via Ethernet cabling without the need for batteries or a wall outlet.

**POTS** means a Plain Old Telephone Service and is a retronym for voice-grade telephone service employing analogue signal transmission for voice services within the home.

**Primary Home Distributor (PHD)** provides a point of connection to external network services and also to local equipment. In the case of an MDU this is referred to as a building frame.

**Premises** is a single building or structure located on a defined geographical site. A premises can contain one potential End User, e.g., a standalone house), or more than one potential End User e.g., apartment building or high rise office building.

**Premises wiring** is the physical deployment of Generic Cabling principles.

**PSTN** means Public Switched Telephone Network which provide "circuit switched" voice and low speed data services where each circuit is held open for the entire call duration. Increasingly replaced by digital access services that provide "circuitless" voice and data services where each packet of data is routed individually.

**RGW** refers to residential gateway which may be provided by the Retail Service Provider.

**Retail Service Provider (RSP)** means any person providing a Telecommunication and/or Broadcast Service to a Customer and who has the Billing Relationship with the Customer for that service.

**RJ45** a generic term used to describe the 8-way modular socket or associated plug originally used in North America and now standardised internationally.

**Service Lead-in** is a term used by some ANPs for a cable or duct installed on private property serving an individual customer from a network terminal or boundary point. In this document the term "Service Lead-in" is used for both individual customer and communal cable from the network to the premises or network distribution point. A Service Lead-in may be installed:

- to a single dwelling
- in a Right of Way (ROW)
- to a Multi Dwelling Unit (MDU)
- to a Commercial Premises.

A communal lead-in is terminated on a network terminal. Individual customer leads-ins are connected an individual customer premises.

**Secondary Home Distributor (SHD)** connects the primary home cabling to secondary home cabling and provides connections to outlets or unit Home Distributors.

**Service Provider (SP)** means any person providing a Telecommunication and/or Broadcast Service to a Customer and who has the Billing Relationship with the Customer for that service. The same person may be both an Access Network Provider and a Service Provider. In this document the Service Provider is referred to as the Retail Service Provider.

**Shielded Twisted Pair (STP)** balanced pair cable with some form of shielding for improved EMC compatibility.

**Single Dwelling Units (SDUs)** means premises containing one residential or commercial occupant/person within its boundary.

**Socket** the term used to describe the specific type of socket component incorporated in a jackpoint or “telecommunications outlet”.

**Star wiring** is an arrangement whereby each jackpoint is separately cabled to a central point, where cross-connect facilities may be provided.

**Structured** cabling multi-purpose high performance cabling systems installed to AS/NZS 3080 or equivalent standards.

**Telecommunication** is the conveyance by electromagnetic means from one device to another of any encrypted or non-encrypted sign, signal, impulse, writing, image, sound, instruction, information, or intelligence of any nature, whether for the information of any person using the device or not. In the context of this document, it typically implies POTS and Data (Broadband).

**Telecommunications Act** means the New Zealand Telecommunications Act 2001 as amended from time to time.

**Telecommunications Cabling** refers to cable for voice and data (the data may be related to video, security, audio, and home automation control).

**Telecommunications Outlet (TO)** means the international term to describe any type of socket or jackpoint into which terminal equipment may be connected.

**Telecommunication(s) Service** refers to any good, service, equipment and/or facility that enables or facilitates Telecommunication.

**Telephone hub** is any form of Commoning facility, typically used to provide terminations where multiple TO's are to access the same telephone line.

**Test termination** is a sealed resistor/capacitor combination previously fitted within an ETP to provide a remote line test capability independent of whether any CPE is connected to that line. Will be removed by fault technician if found.

**TNV (Telecommunications Network Voltage)** is a non-hazardous class of voltage for safety rating purposes, subdivided into three sub-classes.

- TNV-1 normal operating voltages do not exceed SELV (Safety Extra Low Voltage, which does not exceed 42.4 V peak A.C or 60 V D.C.) but could be subject to over-voltages from a network.
- TNV-2 normal operating voltages do not exceed SELV and are not subject to network over-voltages.
- TNV-3 normal operating voltages do exceed SELV and are subject to network over-voltages. Because of ringing voltage and the possibility of mains contacts or lightning transients, a PSTN line and the wiring directly connected to it are rated at TNV-3. Wiring carrying Ethernet is rated at SELV.

**Twisted Pair (TP)** is a common term to refer to UTP (unshielded twisted pair).

**Two-wire (2-wire)** is the present standard BT jackpoint system where one pair interconnects all 2-wire TO's, each of which incorporates a capacitor to ring older 3-wire connected CPE.

**Ultrafast Broadband (UFB)** is a New Zealand Government program of building fibre-to-the-home networks covering 87% of the population by the end of 2022. It is a public-private partnership of the government with four Local Fibre Companies.

**Unit Home Distributor (UHD)** which, in a multi-dwelling unit, connects to external network services and provides connections to outlets in an individual dwelling unit

**UTP (Unshielded Twisted Pair)** the more commonly used type of balanced pair cable (as distinct from STP) in New Zealand.

**Voice** refers to voice services provided over VOIP, POTS or PSTN.



**VOIP (Voice over Internet Protocol)** is a digital form of voice communication.

---

## I. SYSTEM DESIGN RECOMMENDATIONS

### 25. System Objectives

25.1. The minimum premises home wiring requirements that will facilitate a home meeting the Governments Digital Inclusion vision, with future proofing for integrated Wi-Fi if required, refer to Figure 2:

25.1.1. Duct from boundary to house

25.1.2. ETP

25.1.3. Fibre pathway/microduct from the ETP to the Home Distributor location

25.1.4. Home distributor box (plastic)

25.1.5. Two CAT6 cables and outlets to the primary TV position

25.1.6. One CAT6 cable and outlet to each Wi-Fi Access Point position (one Wi-Fi Access Point per 100m<sup>2</sup>, one Access Point per floor, not more than 20m between Access Points) – One of the access points may be the primary TV position or modem position.

25.1.7. Microduct or other 20mm duct to support fibre being installed in the future (installed in parallel with the CAT6 cables) to any potential future ONT position (in this example, the TV position).

**Note:** Duct from boundary to house is not needed for Fixed Wireless Access technology. However, a duct should always be installed to give the owner/occupier the option of connecting to a fibre or copper network.

25.2. The best practice premises home wiring requirements recommended to be installed, refer to Figure 3:

25.2.1. Duct from boundary to house (refer note above)

25.2.2. ETP

25.2.3. Fibre pathway/ microduct from the ETP to the Home Distributor location

25.2.4. Home distributor box (plastic)

25.2.5. Four CAT6 cables to the primary TV position

25.2.6. One CAT6 cable to each Wi-Fi Access Point position (one Wi-Fi Access Point per 100m<sup>2</sup>, one Access Point per floor, not more than 20m between Access Points)

25.2.7. Two CAT6 cables to each non-wet room in the premises

25.2.8. Microduct or other 20mm duct to support fibre being installed in the future (installed in parallel with the CAT6 cables) to any potential future ONT position (in this example, the TV position).

25.3. A full smart home wiring should include all of the above for Best Practice home wiring, plus any or all of the following:

25.3.1. Smart light switches

25.3.2. Smart wall outlets

25.3.3. Smart thermostats

25.3.4. Smart sprinkler controllers

25.3.5. Smart smoke alarms

25.3.6. Smart video doorbells

25.3.7. Other POE devices

**Note:** This list is not exhaustive, but representative of what ethernet cabling can be used to operate. Key devices still require being hardwired, not so they can work with smart home systems, but because they need to communicate with “dumb” appliances. Smart light switches and outlets allow control of what they’re connected to with an app on a smartphone, or through a smart speaker. When installed, a smart switch will control all the lighting on that circuit, and a smart outlet controls whatever is plugged into it (such as a lamp, table fan or other standalone electrical device).

**Figure 2: Minimum Home Wiring**

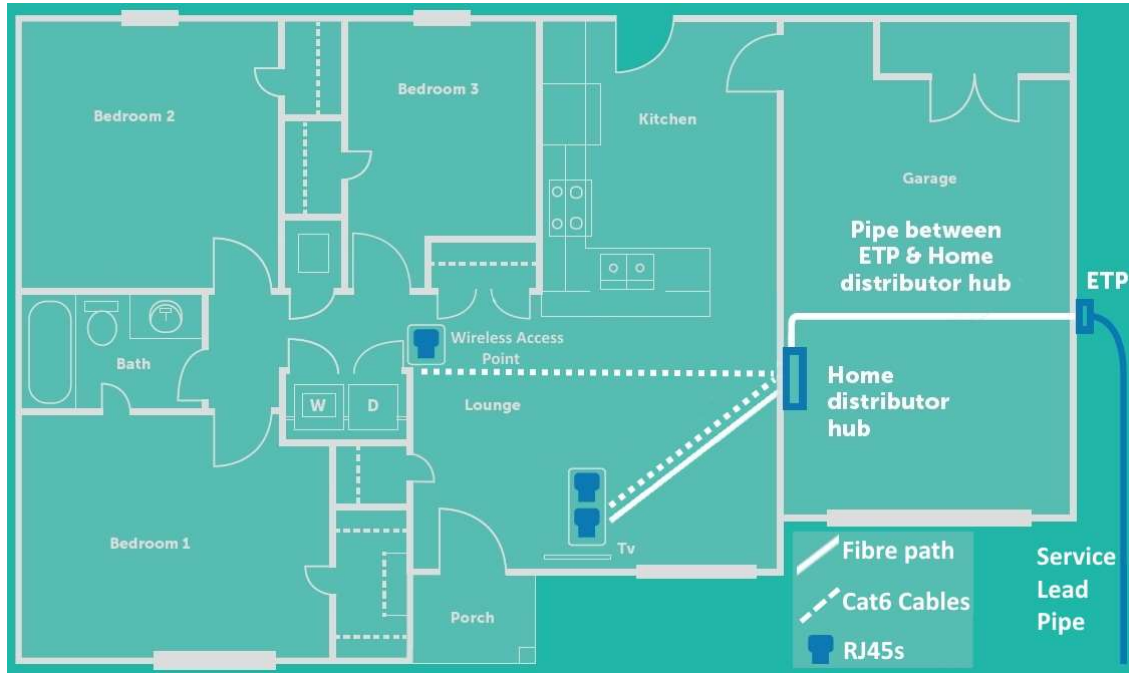

**Figure 3: Best Practice Home Wiring**

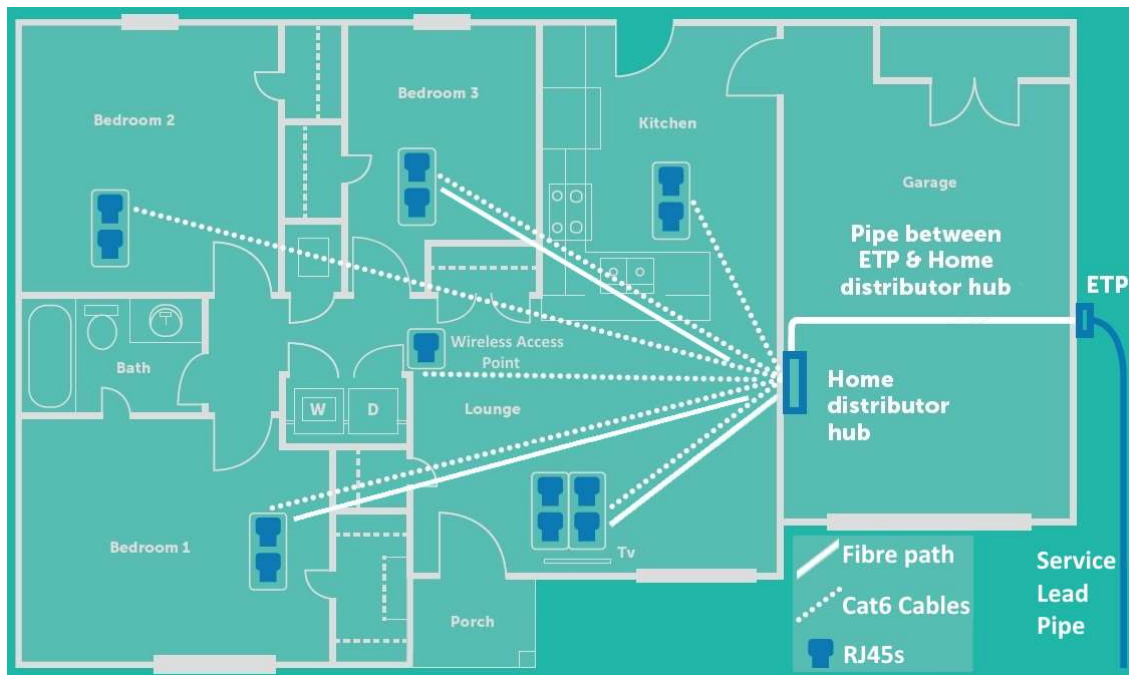

---

## J. GUIDELINES/CONSIDERATIONS

### 26. ONT Location

- 26.1. As outlined in the Home Distributor Location sub-section below, the ANP ONT is required to be situated in a location that meets the same requirements as the home distributor box.
- 26.2. The most likely location the ANP will install an ONT in a house with structured cabling is in the home distributor box. However, the homeowner may require the ONT in another location dictated by optimum Wi-Fi location, such as a home office, or near the main TV or media centre. Structured cabling and future fibre pathways as detailed in this document will allow ONT location flexibility. The ONT will need to be installed near a power source.

### 27. RGW Location

- 27.1. The RGW is commonly the primary Wi-Fi access point for the customer. The installation location should optimise Wi-Fi coverage. A nearby TO will take the broadband signal back to the Home Distributor for connection to the rest of the house.
- 27.2. Connecting Fixed Wireless Access:
- 27.3. If the Home Distributor is located in a location with good mobile coverage, the wireless modem can be placed in or near the Home Distributor and the voice and broadband connections distributed throughout the home using the in-home cabling.
- 27.4. If the wireless modem is better located elsewhere in the premises (e.g., near an outside window) the voice and broadband connections can use a nearby TO to take the signal back to the Home Distributor for connection to the rest of the house.
- 27.5. Optionally the voice service can be provided using DECT phones directly from the wireless modem if physical outlets are no longer required. In this case the voice service does not use the in-home wiring.

**Note:** An ONT is a permanent fixture in the premises, and as such should be installed in a location which means it is less likely to be inadvertently removed. A plastic Home Distribution Box is an ideal location.

### 28. TV Guidelines

- 28.1. As more smart TVs are making their way into homes, access to broadband for content becomes more important. Ideally TVs will have the ability to be plugged into a TO and/or directly into the RGW.

---

## K. SYSTEM DESIGN DETAILS

### 29. System objectives

- 29.1. An objective of any residential wiring system is for all outlets (Telecommunications Outlet) to be general purpose. Telecommunication Outlets (TO) can support a range of applications, depending upon the appliance plugged into it and the service the TO is patched to at the Home Distributor. A TO is therefore an “access point” used to access common network and in-home applications, including:
  - 29.1.1. Telephony services – voice services,
  - 29.1.2. Wireless Data Services - Typically refers to WiFi,
  - 29.1.3. Wireless (DECT) voice handsets (telephones); and
  - 29.1.4. Local Area Networks - –up to 10Gbits/sec Ethernet using CAT6 cable.
- 29.2. The modern wiring system should also incorporate ducts or pathways for additional capacity and/or future technologies.

## 30. Wiring Architecture

30.1. The recommended wiring for a residential Generic Cabling Systems is a star-wired architecture using high performance cables and TO sockets. This is significantly different from traditional analogue telephone wiring which in many cases is wired in a daisy-chain fashion using voice-grade cabling and outlets. The differences in architecture are illustrated by Figures 4 and 5.

**Figure 4: Star Wiring Topology**

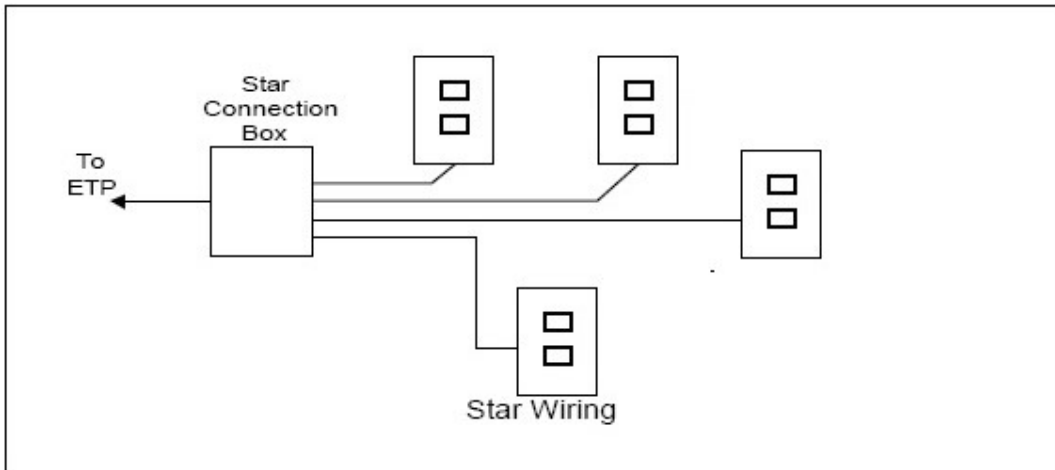

**Figure 5: Historical Wiring Topology Types**

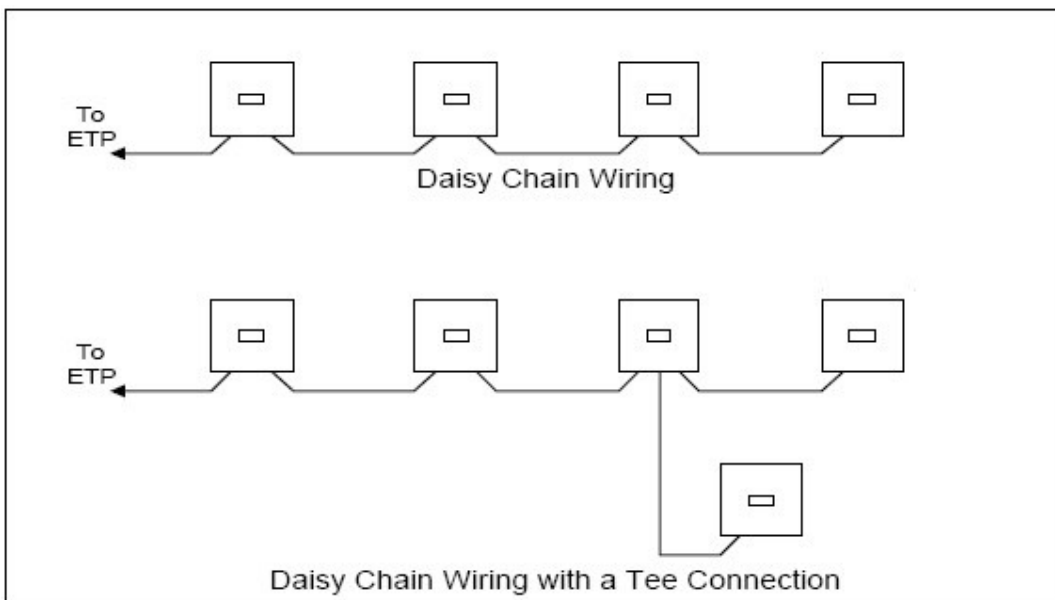

30.2. The data cabling will use the star configuration to enable each TO be connected to a separate port on the Residential Gateway or router, or an Ethernet switch.

30.3. Generic Cabling that is used for connecting telephones, will use a Telephone Hub at the star connection box (refer Figure 4 above) to allow all telephones to access a single incoming PSTN line.

30.4. Historical devices which used line grabbing functions, such as medical, fire and burglar alarms, needed to be connected so that they could seize the lines and make calls even if the telephone line is being used by another device in the house. With voice services more often being provided by derived services now, this has rendered line grabbing devices redundant from new build premises.

**Note:** Line grabbing monitored alarms typically need a working voice line to function. Depending on how the voice service is delivered, battery backup of network equipment may be needed to ensure that the voice line continues to work in a temporary power outage. Some alarms do not work over derived voice services. IP and mobile based alarms are gaining significantly in popularity and are the preferred solution going forward.

## 31. Fibre pathways (ducts or microducts)

31.1. Main fibre pathway: A main fibre pathway is to be provided from the ETP to the Home Distributor location.

31.2. Additional fibre pathways: Additional fibre pathways for future fibre installation are also recommended.

These pathways will allow fibre to be installed further into the premises beyond the Home Distributor.

Pathways are typically Low Smoke Zero Halogen (LSZH) microduct, internal rated microduct with an outer sheath, refer to Figure 6.

31.3. Internal routes should be installed within the following guidelines:

31.3.1. To protect the duct, the safest route must be chosen where the possibility of accidental interference is limited. If installed into the attic space, the cable must not run along the floor (where the cable is prone to damage or being stood on).

31.3.2. Avoid areas used for storage, chimneys, flues, heating ducts, water tanks and plumbing.

31.3.3. The LSZH duct should follow a common route with CAT6 horizontal cable.

31.3.4. For sub floor installations, the duct should run clear of any potential wet surfaces, such as the ground and along areas at the bottom of external walls, bathroom, launderette or any place where any unintentional water leakage or dampness may occur.

31.3.5. The LSZH micro duct / cable must be installed in the least intrusive location possible. Where possible surface cables should be installed in a location that is likely to offer some protection.

31.3.6. Observe the correct bend radius (x20 the duct diameter for microduct, preformed bends for 20mm duct or similar).

**Figure 6: LSZH internal microduct for fibre pathways**



## 32. Alternative to fibre pathways

32.1. An alternative to installing fibre pathways is the use of an armoured fibre cable or composite (hybrid) copper and fibre cable. Suitable products include (as at the time of writing):

32.1.1. Prysmian Optic@t is a combined Cat5e and two fibre cable suitable for use instead of installing microducts. Note: Cat 5e is only suitable for a maximum of 1Gb/s. Fibre companies and RSPs are now selling services in excess of this speed, so relying on the copper component of this cable alone will limit the speeds available inside the premises.

32.1.2. CommScope 3mm 2 fibre armoured cable, available as cable alone, or as part of the Rapid ITP kit.

32.1.3. Flat White LSZH 2 Core G.657 A2 cable. Cable dimension is 3.0mm x 2.0mm

**Note:** A tail of not less than 1m is required at each end of any fibre cable, to ensure there is enough space for splicing.

## 33. Low Smoke Zero Halogen (LSZH) internal Duct Routes

33.1. There are several reasons why flame-retardant LSZH duct is used over Non-LSZH duct:

- 33.1.1. Non-LSZH such as HDPE has been raised as a major fire concern. HDPE duct melts in a fire, turning into molten liquid. Allowing the fire to spread more quickly between rooms (acts as a wick).
- 33.1.2. Burning PE will not only generate almost 3 times more heat but also consume almost 3 times more oxygen and produce significantly more carbon monoxide.
- 33.1.3. Most deaths in a fire are due to inhaling dangerous smoke or gas not the flames themselves.
- 33.1.4. LSZH ducts use materials that do not create halogens or caustic acids, produce little or no smoke, and significantly reduce flame spreading.

### 34. Generic Cabling System Components

- 34.1. Retail Service Providers provision their voice and broadband using a range of different technologies and equipment.
- 34.2. Premises cabled using a Home Distributor can support a variety of Telecommunication Service scenarios by flexibly distributing voice and broadband services to the different TO positions in the building.
- 34.3. Generic Cabling System Components are shown below in Figure 7 and 8, and on the illustrative floor plan for Best Practice Home Wiring, Figure 3 in the Systems Design Recommendations section above.
- 34.4. The physical cabling components of the Telecommunication Service covers:
  - 34.4.1. The Home Distributor which is centrally located with two CAT6 cables to each outlet position, and four CAT6 cables to either the primary TV position or media panel / media centre / entertainment device location where fixed line ethernet enabled devices reside.
  - 34.4.2. At the Home Distributor the CAT6 cables are terminated on RJ45 sockets.
  - 34.4.3. At each TO position the CAT6 cables are terminated on RJ45 sockets

**Figure 7: Generic Cabling System Components – Logical View of Physical Cabling**

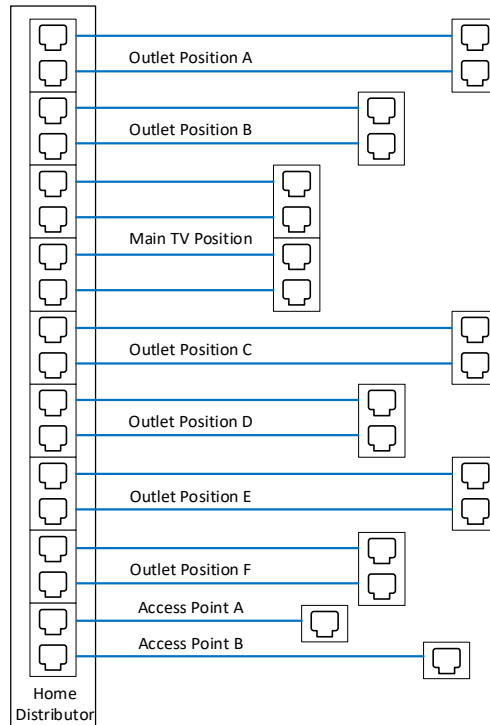

34.5. The following diagram shows a Premises where Telecommunication Services are ready to be connected. The Best Practice Home Wiring schematic, allowing the most flexibility regardless of connection type or service. The common different connection types and Retail Service Provider scenarios are described in Appendix 2.

**Figure 8: Generic Cabling System Components**



### 35. Major System Components

35.1. The key functional elements of a Generic Cabled home are:

35.1.1. Prescribed elements:

- 35.1.1.1. Service Lead-In - the connection to an Access Network Provider (ANP);
- 35.1.1.2. External Termination Point (located outside the premises); and
- 35.1.1.3. Demarcation Points.

35.1.2. Discretionary elements:

- 35.1.2.1. Home Distributor including patch cables and voice distribution;
- 35.1.2.2. Power supplies;
- 35.1.2.3. Internal premises Cabling;
- 35.1.2.4. Ducting; and
- 35.1.2.5. Telecommunications Outlet - RJ45.

35.1.3. Service Lead-In

- 35.1.3.1. The service lead-in is the connection between the premises cabling and an Access Network Provider's network refer to Figure 9. This connection may take the form of a physical aerial or

underground cable, a cable linking to a satellite dish or RF aerial, or a wireless connection that terminates within the premises. Typically, an Access Network Provider may provide up to two network lines, although there is no fixed limit.

**Note:** a service lead in is not required for Fixed Wireless Access services, but ducting is still recommended to allow the resident flexibility to choose their preferred access technology in future.

35.2. Building owners and developers are advised to consult their local Access Network Provider/s to determine the optimum service lead-in option. Options may include copper or fibre service lead-in cables; aerial or underground; the position for the ETP and other special requirements that may need to be addressed.

35.3. The Access Network Provider may provide service lead-in pipe, and/or aerial and underground service lead-ins; however, any such investment will depend upon the circumstances of each case and must be confirmed with each Access Network Provider.

**Figure 9: Service Lead-in and ETP termination**

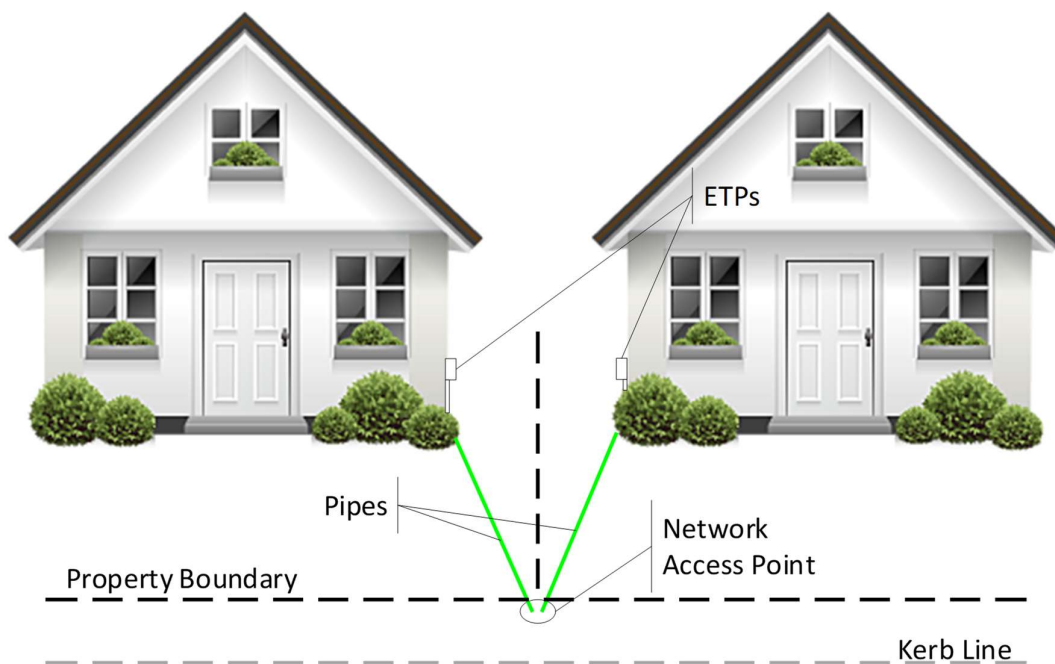

## 36. Underground service lead-in cables or pipe

36.1. The provision of suitable trenching for all services is the responsibility of the premises owner or building contractor acting on the premises owner's behalf. It is strongly recommended that the contractor or his agent consults with the Access Network Provider and the premises owner to determine the most appropriate point on or in the building to fit the Network Termination (typically an External Termination Point or "ETP") and the route for the trench.

36.2. The Access Network Provider may also supply or specify the type of pipe used. Some developers have installed a continuous pipe in an open trench. It is designed for drilling-in. Often this type of continuous product is difficult or impossible for the Access Network Provider to install their cable inside due to not lying straight in the trench before being buried.

36.3. The location and design of the trench must meet the requirement of the Access Network Provider. Failure to meet these requirements may prevent the Access Network from connecting to the premise using the trench and result in the need for further work.

36.4. Service lead-in cable or pipe may share a common trench with other services, subject to adequate protection, service separation and depth which mitigate against hazards or damage.



- 36.5. Where a gate entry system is to be installed for a new building, especially if it has a long driveway, the recommended approach is to co-ordinate the service lead-in and gate entry cable installation with other building services work. This allows the several services concerned to share the service lead-in cable trench, which is paid for by the customer. The gate control installation contractor can then run the necessary control and communication wiring before the trench is closed. AS/NZS3000 restrictions on the sharing of trenches, specifically separation distances (depths), must be observed. It may be preferable to have separate trenches.
- 36.6. The building owner or building contractor acting on the owner's behalf is responsible for back-filling the service lead-in trench, ensuring there is at least 300mm cover over the service lead-in pipe.
- 36.7. In most suburban cases, the network access point is located on alternate section boundaries at the road frontage and the service lead-in cable and/or pipe is run across the premises owner's land to the ETP.
- 36.8. In the case of back-sections, without a public road frontage, it may be necessary for the service lead-in to pass over or under land owned by parties other than the property owner concerned. In such cases, those parties will be required to formally agree to such crossings before any installation work can begin.
- 36.9. Neighbours' crossings will usually require a formal easement to be written into land records, so subsequent owners of the land cannot demand the cable is removed or hinder access to it for maintenance, replacement or upgrade purposes.
- 36.10. MDUs may require individual service lead-ins to each unit (e.g., low rise MDUs) whereas a high-rise MDU is likely to only require a single larger lead-in pipe to a communal network demarcation. Consult with the Access Network Provider to determine how the individual units are going to be connected. (Refer to AS / NZS 3084).

### 37. External Termination Point (ETP)

- 37.1. The ETP is the point at which an Access Network Provider copper service lead-in cable connects to the internal building wiring. For fibre connections, the ETP is a splice point between the fibre service lead-in, and the internal fibre cable. The Fibre ETP is also a NIPA requirement for the UFB network as a test point.
- 37.2. In an MDU, there may be no separate ETP box per-se. The communal service lead-in may simply extend inside the premises to the copper terminal or CLNE.
- 37.3. Typically, the Access Network Provider will supply the ETP and the connectivity within. The purpose of which is to:
  - 37.3.1. For a copper service lead-in cable, provide a physical demarcation point between an Access Network Provider's lead-in cable and the premises wiring; or
  - 37.3.2. Provide a test point for faults diagnoses and network reconnection access without requiring access to the premises, though some faults may still require access into the premises

### 38. ETP Location

- 38.1. The agreed location of the ETP is at the premises owner's discretion, as long as it meets the requirements outlined in this document.
- 38.2. Ideally the ETP will be a box mounted on the exterior of a building by the Access Network Provider providing services to that premises. In some installations it may be located just inside the building or other suitable structure, in which case fault restoration times could take longer due to access issues.
- 38.3. Ideally, the distance between the ETP and any power service drops is no less than 1000mm. However, in practical terms this cannot be met for some new dwellings. An individual risk assessment as to whether the ETP is safe to work on due to its proximity to power needs to be carried out by the contractor/PCBU on site.
- 38.4. The location of the ETP should be as close as feasibly possible to the Service Lead-in cable and/or duct.

- 38.5. The location should allow the lateral duct to be installed into the base of the ETP without exceeding the minimum bend radius; and in a location that will provide clear access and protection to the ETP without the use of ladders or similar.
- 38.6. The ETP shall not be placed in a location of high pedestrian traffic where it is vulnerable to damage.
- 38.7. It is the premises owner's responsibility to provide clear or non-restrictive access to the ETP location, as a one meter working space is required.
- 38.8. The ETP must be mounted between 300mm – 1500mm above the finally intended ground level (unless the premises is served by an aerial service lead-in).
- 38.9. The ETP should not be located below or close to a water tap, where it could be subjected to excessive moisture or mechanical damage.
- 38.10. The ETP shall not be installed in a Gas Hazard area (refer to NZ60079.28).
- 38.11. The ETP for residential and single dwelling units is functionally equivalent to the Building Entry Facility (BEF) referred in AS/NZS11801.1:2019.
- 38.12. The same ETP can be used for both the fibre optic cable entry and the copper cable entry provided that the fibre optic cable bending radius is complied with. However, as the Fibre ETP may be used as a fusion splice point, a Fibre only specific ETP may be used by the ANP.
- 38.13. For new premises, a suitable entry point location for connection of the premises owner's wiring and access route to the PHD/Home Distributor must be selected. The general location is normally arranged with the developer for new subdivisions and is usually obvious from adjacent properties in the area. In cases of doubt, the Access Network Provider will provide guidance on receipt of advance application for service from the owner of the premises.
- 38.14. If not already provided, the Access Network Provider or Retail Service Provider can arrange installation of an individual service lead-in cable or duct and ETP, or a communal service lead-in cable and distribution point for premises requiring a larger number of connections. For buildings where each unit has a street frontage, the ETP location will generally be on the wall facing the street or on a side wall close to the corner with the front wall, with clear access to the Network Access Point on the road frontage. If the ETP is provided by Access Network Provider, the size of the ETP will be determined by the Access Network Provider.
- 38.15. The ETP is provided by the ANP, to ensure the appropriate cable connection can be completed. All ETP's have an interface to the service lead-in pipe installed by the building owner or developer.
- 38.16. The minimum requirement for a new SDU connection from ETP to Home Distributor is either:
  - 38.16.1. A draw wire installed inside a 20mm duct and/or a microduct. This will allow for either copper or fibre cable to be installed by the ANP, depending on the connection type completed. If used, this 20mm duct must have 300mm sweep bends to ensure that any cable, fibre optic or copper can be easily drawn through the duct when required.
  - 38.16.2. A LSZH microduct (no draw wire required). Care must be taken to ensure duct integrity is maintained, and minimum bend radius is not exceeded.
  - 38.16.3. Further information on ducting can be found later in this document.

## 39. Demarcation Point

- 39.1. The demarcation point between the Access Network Provider and the premises owner will vary depending on the type of service lead-in cable that is used and is subject to the Access Network Provider's distance limitations.
- 39.2. For a copper service lead-in cable, the demarcation point will be either:
  - 39.2.1. The External Termination Point (ETP); or

- 39.2.2. Where there is no termination point external to the premises, either the first jack on the premises wiring or, where appropriate, the building distribution frame; or
- 39.2.3. Where a lead-in is terminated on a network terminal. Customer service leads are then connected to this network terminal.
- 39.3. For a fibre optic service lead-in cable in a SDU where the ONT is provided by the ANP, the Demarcation Point will be the outlet ports on the ONT (Ethernet and/or Voice ATA).
- 39.4. For a fibre optic lead-in cable in an MDU, the demarcation point between the Access Network Provider and premises wiring will be either:
  - 39.4.1. As per a single dwelling unit where each unit of the MDU has a separate service lead-in cable; or
  - 39.4.2. The lead-in cable is terminated on the distribution frame that services the MDU.
- 39.5. For MDUs, the demarcation between the building owners' wiring and the unit's wiring shall be in the unit's Home Distributor.
- 39.6. For Wireless or Satellite connections, the demarcation point will be the plug that connects into the wireless modem or satellite dish.
- 39.7. The dark fibre demarcation point is at the internal termination point (ITP) recommended to be within the home distributor.

## 40. Special Cases

### 40.1. Network Demarcation Point:

- 40.1.1. Customer Located Network Equipment (CLNE) & Service Delivery Points: although the access network physically ends at the network demarcation point, there will be situations that require network equipment to be installed within the premises owner's premises to support network services. Whether or not such equipment is connected via customer-owned wiring to the ETP, the premises owner's side of this equipment is termed a "Service Delivery Point".

### 40.2. Service Delivery Point:

- 40.2.1. Where necessary, the Access Network Provider(s) may define the type of network equipment and its location (Service Delivery Point) according to the service's application. In most cases, such equipment is supplied, installed, and commissioned by the Access Network Provider as an inherent part of providing the service concerned.

40.3. Depending on the type of equipment concerned and the space available, such customer located network equipment may be housed within the Home Distributor, with the relevant service delivery point(s) then connecting into the home cabling system via patch cords.

40.4. For unbundled customers on a fixed line connection, the demarcation between ANP network and premises wiring will potentially become murkier. The Unbundler will look and act like an ANP up to the ONT. Then effectively there are two demarcations: Between Wholesale ANP and Unbundler, and between Unbundler and Premises Wiring. This document only references external network as background and when describing interface points.

## 41. Multi Dwelling Unit (MDU)

42. The following paragraphs refer to MDUs that utilize a common communal service lead-in facility. Where MDUs have separate individual customer service lead-in facilities, they shall be treated as SDUs.

Note: A service lead in is not required for Fixed Wireless Access services, nor equipment in a common area, but ducting is still recommended to allow flexibility of preferred access technology in future.

43. Common Areas:

- 43.1. The common area must have suitable space for the installation of the Demarcation Point and termination of the distribution cabling and be sited such that there is access to suitable ducting to the street to provide for installation of the Access Network Provider/s cabling and easy access to the building service riser or cable way.
- 44. In MDUs, the primary function of the building frame is to provide a Demarcation Point and reticulate to the secondary Home Distributors.
- 44.1. Provision of space shall be made to accommodate the common services telecommunications requirements. Such requirements may include space for equipment to support the following:
  - 44.1.1. Building alarm connections;
  - 44.1.2. Lift telephones;
  - 44.1.3. Building HVAC monitoring;
  - 44.1.4. CCTV security monitoring; and
  - 44.1.5. Building access control.
- 44.2. The Access Network Provider may have additional requirements for a building frame such as the installation of optical splitter equipment to enable each Unit to be served by its own dedicated fibre service. Alternatively, the Access Network Provider may install a larger rack mounted ONT that serves all the Units within the building. It is recommended to consult the Access Network Provider on the requirements of the building frame.
- 44.3. If fibre is reticulated from the building frame to the secondary Home Distributors, the Access Network Provider may install a single shared ONT on each floor to serve a number of Units or if fibre is available to each Unit, install a dedicated ONT within each Unit.
- 44.4. AS/NZS 3084 provides further guidance and sizing for common areas.

## 45. MDU Generic Cabling

- 45.1. Options for a new MDU premises:
  - 45.1.1. The Access Network Provider(s) to provide their own cabling to each floor of the MDU and feed a Home Distributor in each unit that contains the Access Network Provider's ONT and Demarcation Point, or
  - 45.1.2. The Access Network Provider(s) cables and demarcation in a common area in the MDU with customer owned building distribution cable feeding each dwelling unit, or
  - 45.1.3. The Access Network Provider(s)' cabling and demarcation on each floor of the MDU with customer owned building distribution cable feeding each unit.
  - 45.1.4. A combination of b and c above is suitable for existing MDU premises.

## 46. MDU Cable Ownership:

- 46.1. The Access Network Provider controls the service up to the Demarcation Point.
- 46.2. The building owner/customer will own the premises distribution cable within the tenancy and the Unit's Home Distributor if required.
- 46.3. Suitable access ducting:
  - 46.3.1. Access ducting from the street into the MDU common area should be decided in consultation with the Access Network Provider(s). Consideration may need to be given to multiple lead-ins from different network access points for the purpose of redundancy.

## 47. Home Distributor (SDU and MDU)

47.1. The Home Distributor is the central point at which all internal premises wiring terminates and branches out from. It is also the location at which cross connections can be made to external (broadband) or in-home (LAN) services. Refer to Figure 10 below.

**Figure 10: The Home Distributor**

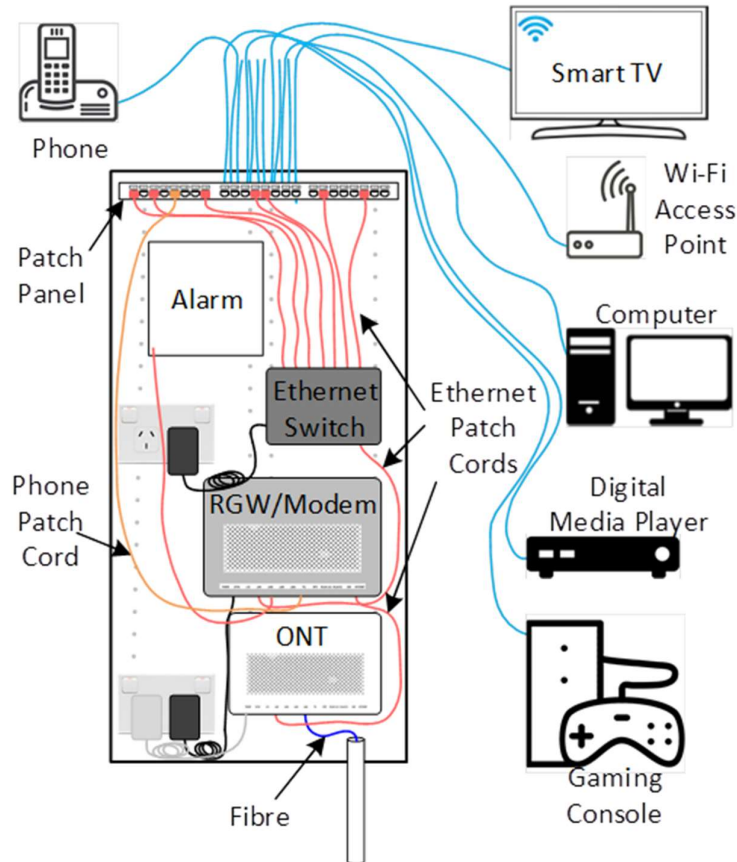

47.2. The Home Distributor typically houses:

- 47.2.1. A separate cable to each TO on the premises. Looping (Daisy-chain) to subsequent TOs is neither a common nor desired practice;
- 47.2.2. Commoning and cross-connection facilities, including patch cords;
- 47.2.3. Other relevant communication, control and networking hardware e.g., router, Ethernet switch, alarm, hub, etc;
- 47.2.4. Records needed for the effective management and operation of the installation;
- 47.2.5. A point of interconnection for voice and data services and applications;
- 47.2.6. Optical Network Termination (ONT) devices for fibre optic cable provision; and
- 47.2.7. Power distribution facilities where Power Over Ethernet (POE) devices are used through the premises.

## 48. Home Distributor Location

48.1. The Star wiring box or Home Distributor should not be placed in the roof or sub floor space as a central distribution point. The temperature operating range for most ONTs and other active equipment is 0°C to 40°C which may fall outside the temperatures encountered within the subfloor or ceiling space. This combined with issues surrounding accessibility and potential damage from rodents. Be aware of any

potential problems that may arise due to the Home Distributor location. Any liability rests solely with the Homeowner if these recommendations are not followed.

- 48.2. The Home Distributor, which is where the ONT is most likely installed, should be placed in internally in a location where:
  - 48.2.1. It is dry (and in an area where it is not subject to splashes, steam and condensation).
  - 48.2.2. Is well ventilated.
  - 48.2.3. It is not subject to accidental damage.
  - 48.2.4. It is accessible (in case of ONT reboot).
  - 48.2.5. It is in a location that is within the ONT operational temperature range.
  - 48.2.6. An adequate level of lighting and where possible 1m of clear space in front of the Home Distributor to help enable maintenance and user access.
- 48.3. If the modem is likely to be placed in another location, then ensure that location has at least two TO's (but preferably four), to allow signals to be routed back to the Home Distributor.
- 48.4. In the situation where the Home Distributor is of metal construction any Wi-Fi device installed inside the Home Distributor will have significantly reduced Wi-Fi performance. It is recommended that any device supplying Wi-Fi signal should NOT be installed within a metal Home Distributor. A plastic or composite Home Distributor box is recommended, and Wi-Fi devices may be installed within the Home Distributor box or elsewhere in the premises.
- 48.5. The Home Distributor is essentially a cabinet, mounted in or on a wall, or a cupboard in which the cable termination hardware and other components are housed. Equipment within such a cupboard may be wall or rack mounted.
- 48.6. It is recommended that a Home Distributor be installed in all new homes and any existing premises undergoing major refurbishment and is ideally located on an inside wall immediately behind and above the ETP position. The location of the ETP should be discussed with the chosen Access Network Provider. Refer to section 28.
- 48.7. It is recommended that the top of the Home Distributor be installed no higher than 1.85m from the ground/floor.
- 48.8. Home distributors installed in the wall cavity should be large enough to adequately store the cable termination hardware and other components, at least 700mm (high) x 350mm (wide) x 80mm (deep). While stand alone or surface/wall mounted or Rack (19") mounted distributors should be least 700mm high and 300mm deep. However, where practical it is recommended that a larger cabinet be installed to accommodate any future hardware and componentry.
- 48.9. It is envisaged that existing residential and SDU premises will transition, through a series of stages, to a full Home Distributor over an extended period of time. The first stage may be as simple as installing a multi-point faceplate from which traditional PSTN and new TP CAT6 cables radiate out from and to which modems, network hubs and gateways connect to deliver service. Refer to Appendix 1.
- 48.10. In existing homes where a Home Distributor box is being retrofitted, where access to the wall behind the ETP is not practical, the Home Distributor should be mounted as close as possible to the ETP (on an inside wall), or arrangements made to shift the location of the ETP.
- 48.11. The Access Network Provider may have a maximum distance that the Home Distributor can be from the ETP before it is classified as a non-standard install and therefore may incur additional installation charges. Consult with the Access Network Provider on the maximum internal distance between the ETP and the Home distributor.
- 48.12. In larger premises secondary Home Distributors may be installed to facilitate cable reticulation and service management. In MDU premises each unit must have its own building frame, which, in a MDU,

connects to external network services and provides connections to outlets in an individual unit. SDU premises should have rack mount distributors.

48.13. Home Distributor general installation recommendations:

- 48.13.1. The Home Distributor should not be located in an area subject to condensation such as a bathroom, kitchen or laundry.
- 48.13.2. The Home Distributor must have adequate ventilation or forced cooling to allow for the continuous operation of any installed electrical equipment e.g., venting in door or cabinet with adequate airflow. Active electrical equipment such as the ONT and router will generate heat.
- 48.13.3. An adequate level of lighting should be provided to maintain the Home Distributor and there should be at least 1m clear space in front of the Home Distributor to facilitate maintenance and user access.
- 48.13.4. All Home Distributors must allow for the isolation of premises wiring from external networks. This enables simple tests to determine whether a fault or possible performance issue is in the external network or the premises.
- 48.13.5. Provision should be made for a connection point so that either a DSL splitter may be installed where DSL Broadband and traditional telephone (PSTN) services are delivered over the same copper pair, or a Gateway device installed where broadband and voice services are delivered via the DSL (Naked DSL) circuit.
- 48.13.6. The Home Distributor shall include provision for connecting a "Line Grabbing" alarm system between the Service Provider Line and the Telephone Hub. A typical implementation is shown in Figure 2 or 3. Alternatively, an IP or mobile based alarm can be installed.
- 48.13.7. An installation should bear a label issued by a qualified installer that the entire wiring system complies with the AS/NZ 11801.1:2019.
- 48.13.8. The quality of the components installed will impact future performance and life expectancy of the system. It is strongly recommended that only components that have been independently certified by a recognised body, such as the Underwriter's Laboratories (UL), be used.

#### 49. Generic Cabling termination hardware within the Home Distributor

- 49.1. RJ45 patch panel hardware should be used. It is strongly recommended that only patch panel hardware and patch cables supplied by recognised Generic Cabling manufacturers and independently certified by a recognised body such as the Underwriter's Laboratories (UL) be used. Similarly, the recommendations of suppliers for the installation, testing, use and management of this hardware should be followed.
- 49.2. Only certified "multi use" Insulation Displacement Connectors (IDC) RJ45 sockets should be used.
- 49.3. Fibre optic sockets should contain SC/APC type connectors that are housed in a purpose-built enclosure that incorporates a shutter that provides a high level of laser safety.
- 49.4. Cross-connections:
  - 49.4.1. For consumers with little technical knowledge Ethernet patch cords are a practical approach to forming cross connections, as no special tooling is required, and cross-connections are easily carried out so long as connection points are clearly marked.
  - 49.4.2. For long-term reliability it is strongly recommended that RJ45 patch cords be factory-terminated and of such a length that there is plenty of flexibility for movement, but it is not necessary to coil up surplus within the Home Distributor.
- 49.5. While it may initially be cheaper to terminate appropriate short lengths of cable "on-site", such connections can prove unreliable in the longer term. In particular, the use of solid conductor cable as patch cords often proves unreliable where the patch cords are subject to movement during the service life of the installation.

- 49.6. Flexible factory assembled patch cords should preferably be used to ensure that subsequent movement during re-connection work will not result in failed connections.
- 49.7. Where cables or cords are “on-site” terminated, it is important that the correct type of plug and crimping tool is used. Plugs intended for use with flexible cords are not suitable for use on solid core cable, nor are those intended for solid core cable suitable for flexible cords.
- 49.8. Where a service lead-in is not terminated directly onto the Optical Network Terminal (ONT) but to the fibre socket the connection will be with a SC/APC to SC/APC patch cord.

## 50. Hardware for other services within the Home Distributor

- 50.1. The Home Distributor may also house a router for home Local Area Network (LAN) operation, along with its power supply; television distribution hardware (coaxial cables, amplifier, splitter and power supply); infra-red remote controls for the AV system; a security system or medical alarm connections.
- 50.2. There is no constraint on what hardware is fitted within the Home Distributor as long as it facilitates ease of operation; the cabling should be installed in a tidy and uncluttered manner with adequate clearance between components to ensure electrical interference is minimised, and adequate cooling is provided.
- 50.3. Active devices in Home Distributor will need power connection, the electrical points, either a single dedicated wall plug, or multi-plug board should be installed in a manner that enables the door can be closed when plugs are installed. (For safe use of multi-boards, reference ‘Worksafe’, Appropriate use of power boards).

## 51. Power Supply

- 51.1. Telecommunications Services delivered to End Users using technologies such as fibre, fixed wireless, cable, satellite and some copper services (VoIP), will not operate in the event of a power outage.
- 51.2. It is recommended that an Uninterrupted Power Supply (UPS) device with surge protection is installed to provide power backup during power outages, and ensure service continuity for telephones, alarm systems and other home mission critical services.
- 51.3. If continued operation is required, all essential parts of the service will need to be powered by the UPS to ensure service in the event of a power disruption. For fibre, depending on how the voice is provided by the RSP, this may mean both the ONT and RGW will need to be powered.
- 51.4. In addition, the Commerce Commission’s 111 Contact Code<sup>2</sup> requires RSPs to have a scheme in place to protect Vulnerable Consumers who have a particular risk of needing to call emergency services. Those who qualify will be provided with an alternative means to access 111 emergency services in the event of a power failure. Customers should contact their RSP for more information on their scheme and how to apply.

## 52. Generic Cabling

- 52.1. An installation may make use of a range of technologies and practices, including:
  - 52.1.1. CAT6 Twisted Pair (TP) cable is recommended and RJ45 connectors at the equivalent standard, primarily for telephony and data, but also capable of supporting other services, such as audio and video, home control, etc;
  - 52.1.2. To further future proof the premises fibre optic cable can be used instead of CAT6 cable. This may require the use of media convertors to provide services within the premises;
  - 52.1.3. For MDU consideration should be given for the installation of a fibre-optic cable distribution system between the building frame and the secondary Home Distributor. This system should terminate in a common area with dedicated fibres to each unit, a minimum of two fibres per unit is recommended; and

---

<sup>2</sup> <https://comcom.govt.nz/regulated-industries/telecommunications/projects/commission-111-contact-code>



52.1.4. Cabling to devices to provide Wireless services, such as Wi-Fi and cordless telephones.

52.2. A Generic Cabling system is a system that is designed to conform to a set of rules providing support for multiple applications and is typically a system based on high performance 4-pair TP cable wired in a star wiring configuration.

### 53. Performance characteristics of TP cabling

53.1. The performance characteristics of TP cabling commonly used in residential and commercial communications applications is expressed by its design or UTP Category (Cat) rating, the most common being:

	Maximum Length (meters)	Speed				POE	Mhz
		10 Mbps	100 Mbps	1 Gbps	10 Gbps		
Cat3	100	✓					16
Cat5	100	✓	✓			✓	100
Cat5e	100	✓	✓	✓		✓	100
CAT6	100 55 for 10Gbps	✓	✓	✓	✓	✓	250
CAT6a	100	✓	✓	✓	✓	✓	500

**Note:** Flat/twin 2, 4, 6 and 8 wire cable used historically is not suitable for data and are suitable for analogue voice only.

53.2. CAT6: performance to 250MHz to support 1 Gbps Ethernet, with a maximum allowed length of 100 meters. This consists of 90 meters of cabling plus and an allowance of 10 meters for terminations and patch cords. This cable is recommended as a minimum standard for all new cable installations. CAT6 (UTP) or better if spans exceed 50m. The maximum lengths of the home cabling are specified in AS/NZS ISO/IEC 11801.1:2019 "Information technology - Generic cabling for homes".

Note: All cabling systems both fibre optic cable and Twisted Pair needs to be correctly installed and maintained if prescribed performance levels are to be realised over the installation's planned life.

### 54. Internal Generic Cabling

- 54.1. All cables, TO's and hardware used in wiring residential premises should be compliant with the relevant industry standards and carry a recognised international independent assessment body of quality and safety e.g., Underwriters Laboratories (UL) or an equivalent New Zealand body.
- 54.2. Cable should be 4-pair of CAT6 or higher performance for both residential and commercial wiring, since this is now the recognised minimum industry standard. All such cable should have nominal 0.5mm diameter conductors and its sheath should bear an industry-recognised certification mark and performance rating in accordance with international standards.
- 54.3. All cable runs should be continuous without joins.
- 54.4. The entire cable run must be replaced if it is damaged in order to maintain performance.
- 54.5. Avoid placing CAT6 cables adjacent to power and always maintain electrical separation. If it is necessary to cross electrical cables, the installer should maintain a 90° angle.
- 54.6. Avoid installing CAT6 cables in proximity to microwaves, air conditioning and any other appliances which are prone to generating RF impulse noise when they switch on and off.
- 54.7. Avoid installing CAT6 cables in proximity to halogen and LED drivers (power supplies) which are prone to generate RF noise.
- 54.8. It is recommended that dual RJ45 TO's be provided at each proposed television set location for either connecting a SKY decoder, connected media devices or smart TV. This is easily accomplished with the various makes and styles of modular faceplates used for electrical installations. These replaceable modules also avoid the need to replace a complete assembly should one or other parts fail in service. High performance 4-pair screened cable using screened TO's and other components rated at CAT6 or Cat7, may

be used for television, video and audio distribution, as well as for data and telephony. Where these components are used, the relevant manufacturer's recommendations are to be followed.

54.9. MDU Fibre Optic Distribution Cable:

- 54.9.1. Fibre-optic distribution cabling within a MDU should be distribution type with either sufficiently robust construction or sufficiently well protected to withstand physical damage. The fibre should conform to the Standard ITUT G.657A2 (Bend insensitive). This outer sheath should be of a Low Smoke Zero Halogen (LSZH) type.
- 54.9.2. These cables are excellent for indoor use. They do not provide the best moisture and environmental protection and therefore are not recommended for outdoor applications.
- 54.9.3. Where fibre optic cabling is being installed for future termination by the ANP, ensure at least 1.2m of slack is left at each end to enable the fibre to be fusion spliced.

54.10. Cable used for wiring outdoors should be purpose made "external" cable:

- 54.10.1. Typical outdoor CAT6 cables are either dry core water blocked (using water blocking yarns) or Gel filled cables and have solid (not stranded) conductors. "Buried" and "self-supporting aerial" types are available.

54.11. Screened Cable:

- 54.11.1. Whilst the use of UTP is typical standard practice, shielded twisted pair (STP) types may be used in conjunction with shielded sockets and other shielded components where shielding is the basis of a commercial design and all components are installed by suitably trained and skilled staff.

## 55. Ducting and microducts

- 55.1. Installing ducting and/or microducts involves the installation of purpose designed and installed (pipes) ducts) to aid the reticulation and installation of new or replacement of wiring in and around premises. These pathways provide flexibility and futureproofing to premises at the time of construction.
- 55.2. During the planning phase of any Generic Cabling installation serious consideration should be given to the installation of ducts to areas that would prove difficult or impossible to install cables once the building is finished. The marginal cost of installing ducts may prove a valuable investment considering:
  - 55.2.1. The financial and aesthetic costs of installing cables into difficult to reach locations once the building is completed;
  - 55.2.2. The ability to replace cable as a result of damage or change of requirements;
  - 55.2.3. The inconvenience costs to homeowners and occupiers of not being able to utilize services in room and locations they wish;
  - 55.2.4. The insulation, sound proofing and moisture blocking integrity of building systems (walls) may be compromised if improper cabling practices are used in a retrofit situation;
  - 55.2.5. The inability of a fibre company to push a fibre optic cable further into the customers premises to provide a fibre-based service in the position the customer requires it.
- 55.3. When deciding to use ducts, careful consideration should be given to the number of cables to be installed in the duct and the impact that future installations may have on the capacity of those ducts. A duct in a straight run is considered to be at capacity when 50% occupied. If there are two bends up to 90° radius in the duct pull length, then it is considered to be at capacity when 40% occupied.
- 55.4. Consideration should be given to installing larger ducts, more ducts and/or a larger bend radius to allow for future cabling. For example, the bending radius required for optical fibre cable is greater than that required for twisted pair cable.
- 55.5. Conduits, ducts and trunking may be made of plastic, aluminium or galvanized steel. (Ferrous metal construction will give superior protection from EMI, provided that continuity is maintained).

- 55.6. Mechanical continuity must be maintained through joints in metallic conduits, ducts and trunking. This enables electrical continuity to be maintained as the conduit, duct or trunking system must be earthed in accordance with AS/NZ3000.
- 55.7. Conduits and trunking should have all sharp edges removed from their internal surfaces. (This minimizes the risk of damage to the cable sheath).
- 55.8. Indoor running conduit should contain draw boxes at distances of  $\leq 30$  meters, Figure 11. If distances between draw boxes exceed 30 meters, a larger sized duct should be used for the runs. The draw boxes must be large enough to permit the minimum bending radius of the largest installed cable to be maintained. (These requirements are to allow for ease of installation. They also allow for drawing through additional cable at a later date and minimize the stress on the cables during the installation. Maintaining the minimum bend radius specified by the cable manufacturer is a mandatory requirement).

**Figure 11: An Example of Draw Boxes**

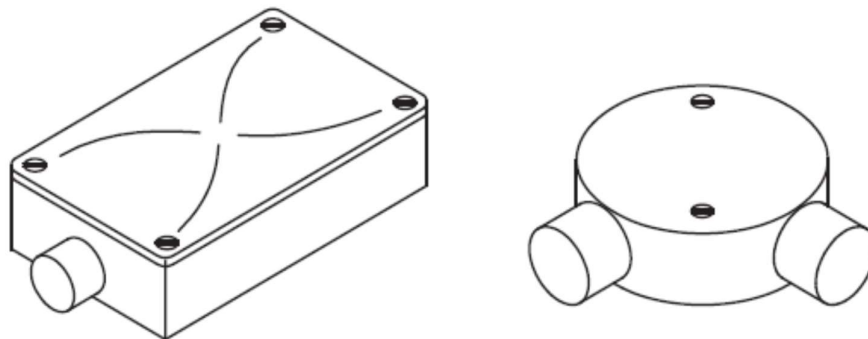

## 56. Telecommunications Outlet (TO)

- 56.1. Telecommunication Outlets are essentially “general purpose” and may support a range of services, depending on how they are connected at the Home Distributor. Each TO can provide a connection point for the transmission and/or reception of information, depending on the type of equipment connected to it.
- 56.2. The total number of TO’s that may be installed in any premises is not restricted. The installation of TO’s on a lavish basis is encouraged as a way of meeting unplanned future requirements, and at a minimum, consideration should be given to having at least two TO’s a room to provide for more than one option for the placement of communication/television equipment.
- 56.3. The number of outlets recommended has been based on the following requirements at a typical TO location e.g., Bedroom:
- 56.3.1. Two RJ45 outlets that can be used for either voice or data services.
  - 56.3.2. Installation of a fibre cable, or future fibre pathway in the form of a microduct.
- 56.4. It is recommended that two RJ45 sockets be installed at each TO location, with the following regarded as the minimum number to be installed in any new home:
- 56.4.1. at least one set of two in every room normally used by the occupants on a daily basis (kitchen, lounge, rumpus room, study, etc, other than “wet rooms” such as bathrooms, shower rooms, or laundry);
  - 56.4.2. at least one set of two in every room that is intended as a bedroom;
  - 56.4.3. one set of four located within 1 meter of each television or media panel / media centre / entertainment devices location where fixed line ethernet enabled devices reside:
    - a) Combining the four RJ45 TO’s on the same faceplate is recommended for maximum flexibility.
    - b) For feeding ATA/Data back to the Home Distributor from the RGW.

- c) With Power over Ethernet (POE) installed, these TO's can also be used to provide power to the associated equipment, whether it be telecommunications network-related or quite separate items such as security cameras and building control devices. This avoids the need for every TO to be located close to a 230 V power outlet. However, power outlet adjacent to the four RJ45's and any microduct pathways is encouraged.
- 56.5. A fibre cable or future cable pathway in the form of a microduct installed up to and stored behind the TO faceplate. Note, a minimum of one meter slack is required for fibre cable for future termination. Ensure it is loosely looped in behind the wall cavity to ensure no kinks or damage to the fibre.
- 56.6. This is the recommended provision of TO's. It is recommended that due regard be given to the likely needs of the consumer, especially in larger rooms, to avoid long equipment cords, and for those rooms where additional access points are likely to be needed at more than one location. For example, there may be two or more "likely locations" for the television set and/or personal computer in the main family rooms. Installation of pathways (ducts or microducts) allows for future cabling to be installed.
- 56.7. These TO's may also include provision on the same faceplate for audio connectors, or other Extra Low Voltage services.
- 56.8. Hardware Type:
  - 56.8.1. The socket assemblies used in TO's should meet CAT6 or higher performance requirements and be marked with the relevant Category rating.
  - 56.8.2. Any brand or model of RJ45 socket, whether assembled into individual modules with associated IDC connectors, or made up complete with faceplates, may be used as long as such sockets comply with a recognised industry standard and are marked accordingly.
  - 56.8.3. Standard "Keystone" format socket assemblies are recommended where the installation is not wholly based on some proprietary socket system using other than keystone sockets.
  - 56.8.4. The associated IDC connectors must be certified "multiple use" type.
  - 56.8.5. Unshielded TO's are regarded as standard practice, but shielded types may be used in conjunction with shielded cable and other shielded components where this is the basis of a commercial design and installed by suitable skilled staff.
  - 56.8.6. TO's with "tool-less" IDC terminations are recommended where it is likely that subsequent jackpoint installation work will be carried out by premises owners not having the appropriate special insertion tools.
- 56.9. Labelling and identification:
  - 56.9.1. All TO's should be individually labelled, with the same identification at the cable termination in the Home Distributor, so that both cable and TO termination can be clearly associated when connecting new services.
  - 56.9.2. Many faceplates and TO modules do not provide an actual label holder and it detracts from the overall appearance to mark the faceplates. It is recommended that either hardware with removable cover plates be used (e.g., HPM and PDL 600 series faceplates), so that markings can be made on the underlying switch plate; or that a simple convention be used to identify individual TO's on a dual or multi-way switch plate in association with a building layout plan. For example, numbering all TO's from left to right or top to bottom in a consistent manner.

---

## L. INSTALLATION GUIDELINES

- 57. The objective of this section is to provide best practice recommendations and a set of minimal requirements for premises wiring installations.

58. For the benefit of consumers, Cable Installers are urged to follow the recommendations provided in this Document, when considering their customer's telecommunication service requirements.
59. All recommendations and requirements provided in this document are generic, and neutral to any specific vendor or hardware. Where specific vendor or product requirements exceed the requirements stated in this Document, the former should be met.

## 60. Safety Requirements

### 60.1. General Safety Requirements

- 60.1.1. All Generic Cabling should be undertaken safely by the cable installer. Safe electrical industry working practices should be followed, and full compliance with all relevant industry safety standards is required from the cable installers and other stakeholders.
- 60.1.2. Any potential hazards should be identified and mitigated prior to starting each aspect of the work.
- 60.1.3. Special care should be employed where changes to existing installations involve work in dark ceilings, wall cavities and other areas containing power cables, gas and water pipes.

### 60.2. Hazardous Voltages

- 60.2.1. Under normal conditions no hazardous voltages are applied by an Access Network Provider to telecommunication lines. Nevertheless, it is possible for lines to become hazardous at any time from earth potential rise, power distribution system faults, lightning activity, or contact with power wiring within the premises owner's own premises or equipment. The Installer should check for hazardous voltages before carrying out any work on premises wiring.
  - 60.2.2. All the internal telecommunication wiring should be completed before finally connecting to the incoming line.
  - 60.2.3. IDCs should be used wherever possible throughout the telecommunication cabling installation. This is to prevent the consumer and installer from the direct contact with bare conductors and minimising a risk of shock from non-hazardous network voltages, such as ringing. The reflexive action to a LV electrical shock can lead to adverse outcomes, such as person losing balance and falling etc.
  - 60.2.4. To comply with AS/NZS 3000, any metal cabinets used for the Home Distributor must be earthed and LV cabling should be enclosed in a separate compartment to that which houses the ELV or TNV cabling. The TCF recommends the use of plastic or composite Home Distributor boxes to avoid the earthing requirement, and to improve Wi-Fi performance of any device is housed within cabinet.
- 60.3. Under NO circumstances shall Low Voltage (LV e.g., 230 V) sockets, switches or modules be mounted on the same faceplate as TNV or ELV components (voltage levels at which telecommunications and data services operate). The joint Australia/New Zealand Wiring Rules (AS/NZS 3000) require that all faceplates comply with AS/NZS 3112, clause 3.2 of which prohibits mixing of these voltage levels on the same faceplate.
- 60.4. For home use, where small children are present, there is the possibility of a child inserting a finger or a conductive object into an open socket. Although TNV3 (with typical voltages in 42.4V - 90V) is not regarded as "hazardous", the child could receive a shock when ringing voltage is applied to the outlet.
- 60.5. If no CPE is connected to the outlet located within children's reach, it is recommended:
- 60.5.1. that the TO patch cord is removed at the Home Distributor; or
  - 60.5.2. A shuttered socket is used in the TO; or
  - 60.5.3. A "dummy" plug is inserted into the wall socket to close off the aperture.

## 61. Telecommunication Wiring Practices

- 61.1. Generic home telecommunication cabling uses the same components as commercial building cabling, which is designed to provide the required Ethernet performance with cable runs of up to 90 meters. The installation

practices outlined in this section for telecommunications wiring also apply to installation of duct and microduct (where applicable).

61.2. Accepted industry practices should be complied with in order to maintain the telecommunication cable performance. This includes the following:

- 61.2.1. Telecommunication Cable should not be deformed prior to, during, or following installation to maintain high frequency transmission performance characteristics.
- 61.2.2. During installation telecommunication cable should not be jerked or pulled such that the tension exceeds 110 N (approx. 11 kg).
- 61.2.3. There should be no kinks or twists in the installed telecommunication cable. Ensure the cable is unwound off drums correctly – using rollers, a jinker or a spindle. Failure to do this will result in product damage.
- 61.2.4. Bend radius of the installed copper telecommunication cable should not be less than 4 times the cable diameter. Typically, no sharper than 25mm. If installing fibre optic cable, refer to the manufacturer's requirements for the bend radius specifications and if not specified then the minimum bend radius is 10 x the radius of the telecommunication cable as specified in the ITUT-G.652D, or in the case of ITU-T G.657A fibre 10mm.
- 61.2.5. Pairing should be maintained as close as possible to the wire terminations (IDC connections); telecommunication cable sheath removal is to be limited to less than 12mm for CAT6.
- 61.2.6. Telecommunication cable sheaths should not be crimped or distorted by clipping, stapling or cable tying.
- 61.2.7. For new installations where the ANP only has a copper network, even where only one line is initially required, a minimum of 4-pair TP (CAT6) and a draw wire should be run from Home Distributor to the Building Point of Entry (BPE) with at least 1m of slack at the BPE end.
- 61.2.8. In all situations, an accessible telecommunication cable path should be provided between BPE and the Home Distributor to allow for future addition of the telecommunication cables by the access network provider. Such cable path will cater for future installation of FTTP or an additional CAT6 cables.
- 61.2.9. Should any part of the telecommunication cable path between BPE and the Home Distributor be not directly accessible for telecommunication cable addition, a duct or a plastic conduit should be provided as part of the initial installation. The minimum recommended duct diameter is 25mm. The duct should have a draw wire installed which should be secured and labelled at either end. Where the ANP has only a fibre network then the path from the BPE to the Home Distributor can be formed by a suitable microduct. A fibre cable or composite copper and fibre cable can also be run alongside the microduct.
- 61.2.10. This document is primarily concerned with the telecommunication cabling of new homes. As such, the telecommunication cabling is expected to be carried out at the pre-lining stage of the building. While this makes for easy access to the framing for drilling access holes and running the cable, it does bring the risk of the telecommunication cables being damaged by other building operations or being obscured if no aperture is cut in the lining. This leads to the following recommendations:
  - a) To the maximum practicable extent, electrical and telecommunications cabling should be left until the main framing has been completed and weather-protected, and all water and/or gas piping is installed
  - b) All data cables installed inside the walls should be routed to the TO via direct vertical line, allowing the later addition of extra cabling to the same TO. Any holes drilled through timber framing during the initial installation should have a minimum diameter of 25mm.
  - c) As a general principle, TO's should be mounted at the same levels as 230 V power outlets so that any cabling obscured by subsequent wall lining operations can easily be retrieved. Marking the

flush box locations on the floor (with the height of the flush box centreline above floor level also marked if it is not at the usual level) eases retrieval and ensures that the cabling is not overlooked if it is accidentally obscured by lining material;

- d) UTP and coaxial cable should NOT be coiled up in the flush box, but be run past the flush box without unnecessary bending, to be pulled back when it is time to make the terminations.
- e) All cables should be clearly and uniquely labelled at both TO and Home Distributor ends.

61.3. The following recommendations apply specifically to UTP, STP and all optical fibre (glass or plastic) Generic Cabling in residential and SDU premises.

61.3.1. Cleanliness:

- a) All telecommunication cabling hardware should be kept clean during installation, avoiding contact with dirty hands, dust from building operations or other contamination likely to cause premature corrosion.
- b) Following their termination, RJ45 sockets should be protected from dust entry, paint, plaster, etc, until building operations are completed. This can be achieved by protecting an outlet with a plastic cover or wrapping each individual RJ45 socket in a small plastic bag. All ducts and microducts are to be capped or suitably sealed.

61.3.2. Moisture protection:

- a) Particular attention should be given to the prevention and control of moisture entering telecommunication cables through or along their sheaths, which is the dominant cause of wiring faults in typical New Zealand dwellings.
- b) In order to prevent water transported on or within the sheath from reaching the associated terminations and hardware, telecommunication cables should enter terminating hardware enclosures either:
  - from below the enclosure; or
  - Only with a drip loop provided if it is not practicable to enter from below the enclosure.
- c) For surface mounting boxes, this requires telecommunication cable entry at a bottom corner of the rear. For flush mounting boxes, cable entry needs to be from the bottom.

**Note:** While it is obviously not intended, during the life of a building leaks in roofs or wall cladding, around windows, etc, as well as pipe leaks within the building, can lead to water coming into contact with telecommunication cabling. In some cases, the telecommunication cable sheath may absorb moisture or provide a path along which it can travel into the TO and result in service failure due to corrosion. This has proved to be a significant cause of service outages in New Zealand's generally damp climate.

This problem is likely to be more serious with generic cabling because of the closer pin spacing in RJ45 sockets and the unprotected design of some TO's that are available, especially where high frequencies are used for enhanced applications and service degradation rather than complete failure could occur.

61.3.3. General cabling practices:

- a) One dedicated cable, clearly labelled at both ends, should be run from the Home Distributor to each TO.
- b) Joints (or "splices") and tee connections should NOT be made within these telecommunication cable runs or microduct runs. However, it is permitted to terminate a telecommunication cable at either end with an RJ45 plug designed for connecting solid conductors.

- c) Once installed, the location of TO's is relatively inflexible. Moving an existing jackpoint or providing an additional one, would almost invariably require a new telecommunication cable run back to the distribution point, because joints are not permitted.
- d) All conductors of cables from TO's should be terminated on either purpose-designed terminations or RJ45 plugs within the Home Distributor.
- e) At least 300mm of telecommunication cable should be left slack in the wall cavity at both ends of a run following its termination. This should be passed back into the wall cavity to form a "drip loop" such that should any water contact the cable it will not run into the TO.
- f) All 8 conductors of each cable should be terminated, ensuring that pairing is maintained, and wire mapping is in accordance with the Installation Testing section of this document.

#### 61.4. Segregation of Services

- 61.4.1. To avoid the risk of electrical hazard and noise caused by induction, Telecommunications cables must be installed with a permanent separation of at least 50mm from mains power cables in all locations, except where the cables are separated by a rigid barrier, an AS/NZ3000 requirement.
  - a) Either side of the stud is the preferred method of achieving this separation.
  - b) To minimise the risk of electrical interference from mains and switching transients or interference generated by appliances, the recommended spacing is at least 300mm wherever it is practicable to do so.
- 61.4.2. TO's and associated hardware should not be fitted closer than a horizontal distance of 200mm from any fitting on which mains voltage cables are terminated, unless separated by a rigidly fixed barrier. However, there are further restrictions on the use of such barriers, as detailed above.
- 61.4.3. Complying barriers include wall linings, full depth framing in walls and substantially enclosed mounting boxes. Electrical flush mounting brackets and open type flush boxes are NOT substantially enclosed in the above context. Without a barrier, the minimum 200mm horizontal separation applies to both sides of a wall unless the wall cavity exceeds 200mm depth.
- 61.4.4. To minimise the risk of noise by induction, telecommunication cable should not be run closely spaced and parallel to wiring of other services. Where it is not practicable to completely avoid such parallel runs, any length where spacing is close to the minimum of 50mm, should not exceed 3m.
- 61.4.5. Telecommunications cables should cross LV cable at right angles, maintaining the necessary separation by means of securing or by an insulated barrier.

#### 61.5. Telecommunication Wiring under Floors

- 61.5.1. Telecommunication cables should be run clear of potentially wet surfaces, such as the ground, along areas at the bottom of outside walls, bathrooms, showers, water tanks, laundries, and any other areas where unintended water leakage or dampness may occur; unless the cable is specifically rated for this purpose.
- 61.5.2. Connections to telecommunication cables should be made only in readily accessible locations and using purpose-designed terminating hardware.
- 61.5.3. The telecommunication cable should be secured at changes of direction and at intervals sufficient to prevent undue sag and potential contact with subsequent groundwork or snagging during other under-floor operations.
- 61.5.4. Closely spaced clipping along timber should be avoided, unless this is necessary for appearance purposes when the telecommunication cable is exposed to regular view.
- 61.5.5. Telecommunication cables should be secured with plastic saddles not by clipping or stapling to avoid metallic short circuits due to compression of cable.



61.5.6. Large telecommunication cable looms should be cable tied to a centenary wire or cable tray. Another widely used method of telecommunication cable management is staple-tying.

#### 61.6. Telecommunication Wiring above Ceilings and Walls

61.6.1. Telecommunication cables in ceilings and wall cavities should be segregated from power cables as detailed above.

61.6.2. Telecommunication cables in ceilings should be routed clear of areas where potential damage may occur, such as areas used for storage, or around chimneys, flues, heating ducts, water tanks and plumbing.

61.6.3. Telecommunication cables should be routed along timber above the ceiling joists wherever possible, to avoid exposure to any water retained by the thermal insulation used between the joists.

61.6.4. Telecommunication cables above cathedral ceilings and horizontal runs in outside wall cavities should be avoided wherever it is practicable to do so.

61.6.5. In any roof areas where the height exceeds 600mm, telecommunication cable should be laid below or clear of surfaces likely to be stood or knelt on, and should be secured to prevent snagging during later operations.

61.6.6. Telecommunication cables should not be clipped or otherwise secured in wall cavities or other inaccessible areas.

#### 61.7. Telecommunication Wiring Within a Concrete Wall

61.7.1. Telecommunication cables should not be laid directly into concrete walls, floors or ceilings. Where it is necessary for telecommunication cabling to pass through or be carried within a concrete structure, it should be housed within a rigid plastic pipe. Any such pipes should be laid on a slope such that any water running down external walls does not run into the building.

#### 61.8. Telecommunication Cables Surface Mount on a Concrete Wall

61.8.1. The installation should facilitate later removal and replacement of the telecommunication cables, if required. Draw-wires should be installed in all ducts. The duct should be direct strait run. Any given length of duct should not have more than two bends or elbows.

61.8.2. Internal building telecommunication cable should not make direct contact with concrete surfaces, particularly those of outside walls and ground retaining walls. Where exposed surface wiring cannot be avoided, separation from the concrete should be provided by enclosing the telecommunication cable in conduit or trunking, or by securing it to a timber batten with plastic saddles, not by clipping.

#### 61.9. Surface Telecommunication Wiring

61.9.1. As a matter of good trade practice, surface wiring should be limited to those few situations where there is no other option. The premises owner's requirements should be included in building plans, and there should be little need for surface wiring.

61.9.2. In particular, surface wiring should be avoided in areas subject to potential damage, including within 50mm of floors. Wherever possible, surface telecommunication cables should be protected from inadvertent physical damage by running them along the edges of skirting boards, scotia's, architraves, or window and door frames.

61.9.3. Any surface telecommunication wiring should be enclosed in a plastic duct or capping with a recommended minimum size of 16mm x 25mm.

#### 61.10. Telecommunications Wiring Between Buildings on Same Site

61.10.1. Where the telecommunication cable can be run entirely within a fully enclosed access-way, it is deemed to be inside wiring.

61.10.2. Inside telecommunication cable may be run in conduit only where the cable run is relatively short, above ground, sheltered from weather, and the conduit can be supported over the full distance on a convenient surface. Such installation should provide for later removal and replacement of the telecommunication cable, if required.

61.10.3. External telecommunication cable should be used in above-ground locations exposed to weather, and should be attached to a structural surface or adequately supported by a self-contained or separate bearer wire. The route should be clear of potential hazards and potential damage. Any poles used should adequately support a ladder to facilitate maintenance. To facilitate later removal and replacement of the telecommunication cable, if required, external telecommunication cable used for underground runs should be installed in a buried conduit which extends at least 300mm above the floor within an indoor location at each end.

#### 61.11. Wiring to Equipment Exposed to the Weather

61.11.1. Where equipment and its associated telecommunication cabling and wiring are exposed to the weather, all such components should be of a design suitable for this purpose.

61.11.2. Standard TO's should not be located outdoors unless housed in industry standard housings of the appropriate IP rating.

61.11.3. All elements of a data cable system exposed to the direct sunlight should be UV rated.

### 62. Cross-connections and Commoning of TO's for traditional analogue Telephone service

62.1. For telephony, the Home Distributor will usually incorporate some form of commoning hardware to allow several TO's to access the line concerned. There is no limit on the number of TO's that may be connected to the same line.

Note: that the total number of Customer Premises Equipment (CPE) items which will operate correctly on a single analogue line is limited by the sum of the Ringing Numbers (RN) assigned to each CPE item connected to that line. Reliable ringing detection is achieved by ensuring the sum of the individual CPE "RN" does not exceed five.

### 63. Connection of Broadband services

63.1. Cables or equipment must not be connected to an ANP's access network without the ANP's agreement (Section 106 of the Telecommunications Act 2001).

63.2. At time of connecting to the Access Network Provider's network, an installation should bear a label issued by a qualified installer to show that the installation complies with the Access Network Provider's requirements and with AS/NZS 11801.1:2019.

#### 63.3. Connecting DSL

63.3.1. With a Home Distributor and star wiring throughout the premises, the Home Distributor should be used to house an DSL splitter such that:

- a) Any TO can be used to connect the DSL modem; or preferably;
- b) The Home Distributor houses a modem with an integral router or the modem and a separate multi-port router or Ethernet switch, such that any TO's can be used to connect PC's and other equipment with an Ethernet interface; and
- c) Where a central DSL splitter is mounted within the Premises Owner's premises, it should be of an Access Network Provider approved type and should be connected on the network side of all other premises cabling, including line-grabbing devices.

#### 63.4. Connecting Fibre to the Premises (FTTP)

63.4.1. Given that the high-speed broadband services are likely to be delivered to premises via a fibre optic cable, the home distributor need to cater for this type of installation.

- 63.4.2. The Home Distributor enclosure should be of sufficient size to be able to accommodate an incoming duct with fibre cable and connector. It should also be of sufficient size to be able to accommodate a standard size Optical Termination Unit (ONT). For further information please refer to section 31 on the Home Distributor.
- 63.4.3. The Home Distributor should be located as close as possible to the point where incoming communications cabling enters the building. This is to minimise the amount of work and costs associated with an addition of the new services, such as FTTP based broadband.
- 63.4.4. The Home Distributor should also cater for additional fibre pathways or fibre cable installed to allow the ONT to be installed elsewhere in the premises.

## 64. Mounting Hardware

- 64.1. Where the TO is not designed to provide a reasonable level of protection against dust and dirt within the wall cavity, boxes used for mounting TO's and other terminating hardware should preferably be of substantially enclosed construction.
- 64.2. The sides, top and bottom of surface mounting type boxes should be continuous with provision for cable entry at the lower rear.
- 64.3. The sides, rear and top of flush mounting types should preferably be continuous except for small holes, and the bottom should contain a cable entry hole not exceeding 30mm in diameter.
- 64.4. TO mounting hardware should be securely fixed in position. If not screwed to timber framing, it should be rigidly fixed to wallboard using suitable fasteners.

## 65. Faceplates and socket orientation

- 65.1. Standard 230 V style rectangular faceplates matching those of the other electrical fittings in the home are recommended for aesthetic reasons. Those providing for separate modules to be fitted facilitate later replacement of any faulty or damaged modules without replacement of the complete assembly.
- 65.2. Faceplates may be installed "horizontally" (landscape) or "vertically" (portrait), but in all cases the RJ45 socket should be oriented such that the plug latch will be on the underside. This ensures that the contact springs are at the top of the socket and less susceptible to dust or dirt settling on them.
- 65.3. Dual RJ45 TO's at each location are recommended. A larger capacity (four way or six way) modular faceplate allows for the fitting more RJ45s where a television set is likely to be used.

## 66. Copper Cable termination

- 66.1. Wires should be terminated on TO's, commoning and cross-connect facilities only with the correct purpose-designed tool for the hardware concerned. IDC terminations should be used wherever possible.
- 66.2. All four pairs are to be correctly terminated; the wires of a pair should be kept together and should be untwisted to the minimum practicable extent consistent with sufficient length for terminating them.
- 66.3. The following requirements apply to wiring terminations in insulation displacement connectors:
  - 66.3.1. Only strip as much sheath from the cable as is required to terminate the paired conductors (maximum 25mm), leaving the sheath intact as close as practicable to the actual terminations.
  - 66.3.2. Insulated wires should be inserted into the slots with the insulation undamaged in the vicinity of the actual connection, and ensure there is not excessive untwisting of copper cable pairs (no more than 13mm).
  - 66.3.3. They should be inserted individually from the correct direction, specified by the hardware manufacturer.
  - 66.3.4. No attempt should be made to terminate wires of types other than those which are specified for telecommunications wiring.

## 67. Fibre Termination

- 67.1. The Access Network Provider's fibre may be terminated in a variety of methods depending on the cable and terminating practices of the Access Network Provider, namely terminated onto a termination point or terminated in a flexible fibre pigtail that can be plugged directly into the ONT. Provision should be provided for both methods of termination by the ANP technician, by leaving at least 1.2m at each end of any fibre optic cable to allow it to be joined.
- 67.2. The Access Network Provider may provide a microduct, a standard flexible cable or a high bend radius cable from the home distributor to the ETP. The Home Distributor shall be laid out to accommodate a microduct or standard flexible cable with the larger bending radius.
- 67.3. A termination or distribution frame, suitable for the insertion of a minimum of two SC/APC adapters, shall be provided by the ANP. MDUs may require additional adapters and the number required should be discussed with the Access Network Provider. In an MDU situation higher fibre count LSZH cable is deployed. These higher fibre count cables require a larger amount of cable slack left at the termination point. A minimum of 3m is required.
- 67.4. When installed, the ANP fibre adapters will be located so that when the external cable is installed, the connector does not face upwards in order to minimise dust collection within the adapter and it shall not face outwards from the cabinet to prevent optical injury to those working on the cabinet. It is desirable to use adapters with inbuilt shutters to prevent optical injuries.
- 67.5. MDUs may require a lockable fibre distribution frame to prevent tampering of the external fibre cable terminations. The Access Network Provider can provide further guidance of their requirements and they would hold the keys to the lockable frame (splice tray).
- 67.6. Provision for Splice trays shall be provided to enable the lead-in cable to be terminated onto individual customer service lead-ins to each unit. A minimum of two splices is required for an SDU. The number of splices for an MDU will depend on the size of the communal lead-in cable, and the network distribution within the building.

## 68. Wire mapping

- 68.1. There are two standard pin-out options available, commonly referred to as "568A" and "568B". The 568A option is the preferred option in Australia and New Zealand. This option should be used unless there is some specific reason why this is not practicable. Premises Owners should exercise caution when purchasing equipment (CPE) particularly from international sources as it may be wired to the 568B standard and therefore result in an incompatibility issue.

**Figure 12: RJ45 568A Contact Spring Numbering**

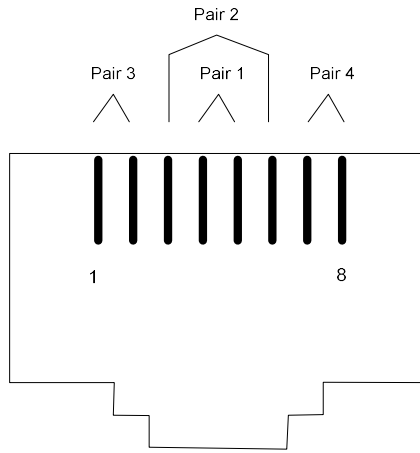

RJ45 Contact Spring Numbering  
viewed from front

NOTE: Actual wire terminations on IDC strips will vary from one manufacturer to another

**Note:** that many RJ45's will show both options usually marked simply as "A" and "B", with the relevant colours shown against terminals and no apparent references to the actual pins connected. The wire to pin allocation for 568A is shown in the table below.

Pair Number	Insulation Colours	Abbreviations	TO Pin Connection
Pair 1	White – Blue	WH – BL	5
	Blue	BL	4
Pair 2	White – Orange	WH – OR	3
	Orange	OR	6
Pair 3	White – Green	WH – GR	1
	Green	GR	2
Pair 4	White – Brown	WH – BR	7
	Brown	BR	8

68.2. Whether the 568A or 568B option is used, the same option should apply throughout the installation. During later cabling additions, the installer should check the existing wiring standard at the patch-panel before any additional TO's are terminated.

68.3. To avoid problems when additions are made, where the 568B option is used, this should be clearly marked on the Home Distributor and in any user instructions or cable records.

## 69. CPE Connection to Copper Wire Network/Service Provider lines

### 69.1. Connection Options

- 69.1.1. Almost all telephones and related CPE now in service and new equipment being offered for sale uses the 6-way plug to BS 6312 adopted by Spark in 1983.
- 69.1.2. Where cabling is installed, it will generally be necessary to either use a suitable adapter to connect such equipment to the RJ45 TO's or have the line cords of CPE concerned re-terminated with RJ45 plugs. This decision is left to the Premises Owner.

- 69.1.3. Where any older 3-wire connected telephones are still in use, these will require a “mastering” adapter with integral 1 microfarad capacitor to provide their ringing function.
- 69.1.4. All CPE must be approved by service or network providers before being connected to that provider’s network.

## 70. Earthing

- 70.1. There is no provision for an earth connection to CPE via TO’s. CPE is deliberately isolated from earth as a safety measure.

## 71. Earthquake Protection

- 71.1. In order for the premises cabling to be used for lifeline service, such as (e.g., calling emergency services) after an earthquake, the installation should be built to earthquake resistant standards.
- 71.2. Equipment, particularly within the Home distributor shall be restrained so that it does not move and damage itself or adjacent equipment.
- 71.3. Power packs that are plugged into 230V outlets shall be secured so that they do not fall out during the earthquake movement.

---

## M. INSTALLATION TESTING

- 72. The objective of this section is to provide guidelines on recommended testing requirements that should be undertaken during the installation and commissioning of the Generic Cabling installation.
- 73. Additionally, to provide guidance to the owner of the premises as to what test certification and compliance documents they should expect to receive, to ensure the installation is fit for purpose.

## 74. Cable Installer’s obligations

- 74.1. Before handing any new or altered wiring installation work over to the property owner, such work must be thoroughly tested to ensure that all wiring is correctly terminated in accordance with the type of jackpoint and termination hardware used. Pair integrity should be maintained. Any defective telecommunication cables should be replaced and termination faults remedied before handover to the property owner.
- 74.2. The installer should ensure conformance to the following:
  - 74.2.1. visual examination of the telecommunication cabling;
  - 74.2.2. verification testing of the telecommunication cabling;
  - 74.2.3. qualification testing of the telecommunication cabling; and
  - 74.2.4. producing a report of results.
- 74.3. Where problems arise, the installer should ensure that all necessary remedial action is taken.

**Note:** The Consumer Guarantees Act 1993 applies ensuring that the installation is suitable for its intended purpose.

## 75. Damage

- 75.1. Telecommunications cabling (e.g., voice, data, video, security, audio, control) can be damaged during the construction phases of framing, gib board installation, and even during the cladding of the exterior. Many of these damaging faults result from causes such as nails and staples penetrating the cable, severe kinks in the cable where the cable was pulled through a drilled hole in a stud or joist, or a cable tear where the cable sheath and conductors are damaged from pulling the cable. Such damage should be avoided, or at worst identified during verification testing, and remedied.

## 76. Visual Inspection

- 76.1. A visual inspection of each cable run should be made after the cable has been installed, but prior to installation of insulation and gib board.
- 76.2. This visual inspection may include but is not limited to:
  - 76.2.1. obvious damage to cable (condition and workmanship);
  - 76.2.2. separation from Electro Magnetic Current (EMC) i.e., power and radio sources of interference (EMI);
  - 76.2.3. incorrect bend radii; and
  - 76.2.4. noticeable excessive cable length.

## 77. Verification

- 77.1. Verification testing is performed after cable placement and prior to the installation of insulation and gib board and must be performed to ensure proper end-to-end connectivity.
- 77.2. Twisted pair cabling verification tests must include:
  - 77.2.1. continuity to the remote end;
  - 77.2.2. length;
  - 77.2.3. shorts between any two or more conductors;
  - 77.2.4. crossed pairs;
  - 77.2.5. reversed pairs;
  - 77.2.6. split pairs; and
  - 77.2.7. any other miss-wiring.
- 77.3. Refer to figure below for an illustration of correct pairing and subsequent figure for several examples of incorrect pairing.
- 77.4. Verification testing to ensure proper end-to-end connectivity is performed after cable placement. Twisted pair cables, such as those used for data and voice, may be terminated on both ends for verification testing and subsequently placed in temporary housings for later finish-out of the cabling.

**Figure 13: Correct Pairing for an Unshielded Twister Pair Cable**

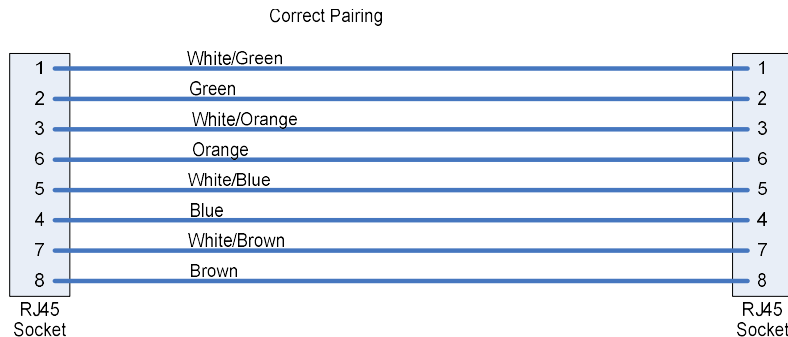

- 77.5. A reversed pair occurs when the polarity of one wire pair is reversed at one end of the link (also called a Tip/Ring reversal). See Figure 14 for an illustration of a reversed pair.
- 77.6. A transposed pair occurs when the two conductors in a wire pair are connected to the position for a different pair at the remote connection. See figure below for an illustration of transposed pairs.

**Figure 14: Examples of Incorrect Pairing**

Reversed Pair

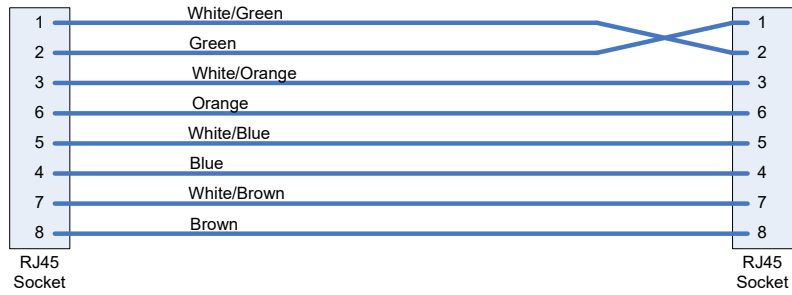

Transposed Pair

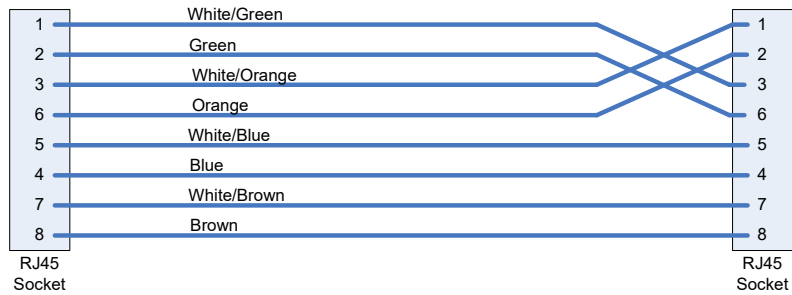

Split Pairs

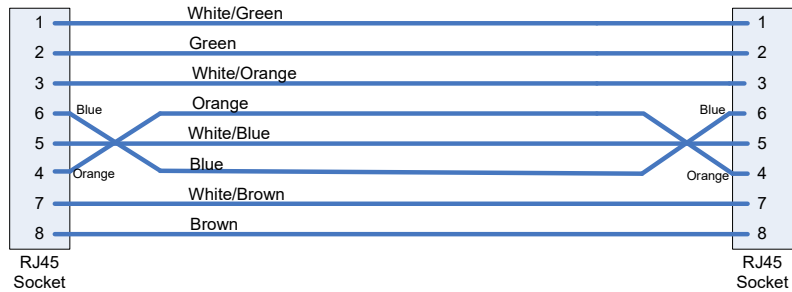

77.7. Examples of cable where they may not be terminated at both ends with an 8-position modular jack are:

- 77.7.1. cable used for powering video cameras, IR targets or IR emitters;
- 77.7.2. audio cable for speakers and volume controls; and
- 77.7.3. Cable for control systems.

77.8. The physical length of the cabling is defined as the sum total of the physical length of the cabling between the defined reference planes. The physical length may be determined by measuring the lengths of the components that make up the cabling. The length of cable segments may be determined from the length markings on the cables. The length can also be estimated from an electrical length measurement. The electrical length is derived from the propagation delay of signals and depends on the twist helix and dielectric material.

77.9. The maximum lengths of the home cabling are specified in AS/NZS ISO/IEC 11801.1:2019 "Information technology - Generic cabling for homes".



## 78. Qualification Testing

- 78.1. Qualification testing should be carried out by the Cable Installer to determine whether the installation is fit for purpose and will support certain network technologies (e.g., 1000BASE-T, 100BASE-T, FireWire). Qualification testing provides confidence to the premises owner that specific applications will work. For example, two cabling runs (cable A and cable B) pass the verification test. A qualification test may show that cable A is only capable of supporting 10BASE-T, while cable B is able to support Gigabit Ethernet.
- 78.2. The qualification tests must be summarized within a documented report generated by the test instrument. A copy of the test results summary must be provided to the property owner and/or tenant and placed in the distribution centre.

## 79. Qualification Test Instruments



















- 79.1. Qualification test instruments must be capable of performing verification testing (wire mapping and connectivity) and qualification tests.
- 79.2. Field test measurements of installed home telecommunication cabling designed in accordance with this document to support AS/NZS ISO/IEC 11801.1:2019 should be performed.
- 79.3. Wire mapping
- 79.3.1. A conductor map test is intended to verify correct pin termination of the 8-pin connectors at each end of twisted pair cabling and to check for installation connectivity errors. For each of the conductors in the telecommunication cable, and the screen(s), if any, the conductor map indicates:
- continuity to the remote end;
  - shorts between any two or more conductors/screen(s);
  - transposed pairs;
  - reversed pairs;
  - split pairs; and
  - any other connection errors.
- 79.3.2. Correct connectivity of telecommunications outlet/connectors is illustrated in Figure 13 (for four pair cables).
- 79.3.3. A reversed pair occurs when the polarity of one wire pair is reversed at one end of the link (also called a Tip/Ring reversal). See Figure 14 for an illustration of a reversed pair.
- 79.3.4. A transposed pair occurs when the two conductors in a wire pair are connected to the position for a different pair at the remote connection. See Figure 14 for an illustration of transposed pairs. Transposed pairs are sometimes referred to as crossed pairs.
- 79.3.5. Split pairs occur when pin-to-pin continuity is maintained but physical pairs are separated. See Figure 14 for an illustration of split pairs.
- 79.4. Qualification Test
- 79.4.1. Qualification tests analyse the network capability of telecommunication cable by injecting signals and analysing their responses, including any interfering signals that are within its field of influence. The resulting analyses of these signals are then compared to known network technology requirements. The result can then be saved to the test instrument for producing documentation, refer to Figure 15 for an example of a qualification test report.
- 79.4.2. The field test equipment must be capable of reporting minimum summary information for each cable run:
- Cable ID;

- b) Date;
- c) Time;
- d) Length;
- e) Wiremap;
- f) Network technologies supported;
- g) Network technologies unsupported;
- h) Test instrument serial number; and
- i) Test instrument use.

**Figure 15: Example of Test Instrument Produced Qualification Summary Report**



*CABLEIQ* Test Results  
Fluke Networks Qualification Tester

<p><b>Site:</b> Smith Residence <b>Address:</b> 555 Main Street Springfield, USA</p>	<p><b>Tested by:</b> Mitchell Installation John Sanders</p>												
<p><b>Written notes:</b></p>													
<p><b>Cable ID: Master Bedroom: 11</b> <span style="float: right;">Written notes:</span></p> <p><b>Qualified:</b> ✓ 1000BASE-T; 100BASE-TX; 10BASE-T; Voice Over IP; Wiremap Only; Telco</p> <table border="1" style="width: 100%; border-collapse: collapse;"> <thead> <tr> <th>Date</th> <th>Time</th> <th>Length</th> <th>Version</th> <th>S/N</th> <th></th> </tr> </thead> <tbody> <tr> <td>1/3/2003</td> <td>3:19:01 AM</td> <td>124 ft</td> <td>V0.05.06</td> <td>8734030</td> <td></td> </tr> </tbody> </table>		Date	Time	Length	Version	S/N		1/3/2003	3:19:01 AM	124 ft	V0.05.06	8734030	
Date	Time	Length	Version	S/N									
1/3/2003	3:19:01 AM	124 ft	V0.05.06	8734030									
<p><b>Cable ID: Living Room: 10</b> <span style="float: right;">Written notes:</span></p> <p><b>Qualified:</b> ✓ 1000BASE-T; 100BASE-TX; 10BASE-T; Voice Over IP; Wiremap Only; Telco</p> <table border="1" style="width: 100%; border-collapse: collapse;"> <thead> <tr> <th>Date</th> <th>Time</th> <th>Length</th> <th>Version</th> <th>S/N</th> <th></th> </tr> </thead> <tbody> <tr> <td>1/3/2003</td> <td>3:19:25 AM</td> <td>52.4 ft</td> <td>V0.05.06</td> <td>8734030</td> <td></td> </tr> </tbody> </table>		Date	Time	Length	Version	S/N		1/3/2003	3:19:25 AM	52.4 ft	V0.05.06	8734030	
Date	Time	Length	Version	S/N									
1/3/2003	3:19:25 AM	52.4 ft	V0.05.06	8734030									
<p><b>Cable ID: Den: 9</b> <span style="float: right;">Written notes:</span></p> <p><b>Qualified:</b> ✓ 1000BASE-T; 100BASE-TX; 10BASE-T; Voice Over IP; Wiremap Only; Telco</p> <table border="1" style="width: 100%; border-collapse: collapse;"> <thead> <tr> <th>Date</th> <th>Time</th> <th>Length</th> <th>Version</th> <th>S/N</th> <th></th> </tr> </thead> <tbody> <tr> <td>1/3/2003</td> <td>3:20:31 AM</td> <td>101 ft</td> <td>V0.05.06</td> <td>8734030</td> <td></td> </tr> </tbody> </table>		Date	Time	Length	Version	S/N		1/3/2003	3:20:31 AM	101 ft	V0.05.06	8734030	
Date	Time	Length	Version	S/N									
1/3/2003	3:20:31 AM	101 ft	V0.05.06	8734030									
<p><b>Cable ID: Kitchen: 7</b> <span style="float: right;">Written notes:</span></p> <p><b>Disqualified:</b> ✗ 1000BASE-T Reason: Wiremap          ✗ 100BASE-TX Reason: Wiremap          ✗ 10BASE-T Reason: Wiremap          ✗ Voice Over IP Reason: Wiremap          ✗ Wiremap Only Reason: Wiremap          ✗ Telco Reason: Wiremap</p> <table border="1" style="width: 100%; border-collapse: collapse;"> <thead> <tr> <th>Date</th> <th>Time</th> <th>Length</th> <th>Version</th> <th>S/N</th> <th></th> </tr> </thead> <tbody> <tr> <td>2/26/2008</td> <td>12:30:32 AM</td> <td>44.0 ft</td> <td>V0.05.04</td> <td>00000005</td> <td></td> </tr> </tbody> </table>		Date	Time	Length	Version	S/N		2/26/2008	12:30:32 AM	44.0 ft	V0.05.04	00000005	
Date	Time	Length	Version	S/N									
2/26/2008	12:30:32 AM	44.0 ft	V0.05.04	00000005									
<p><b>Cable ID: Bedroom #2: 6</b> <span style="float: right;">Written notes:</span></p> <p><b>Qualified:</b> ✓ 10BASE-T; Wiremap Only; Telco  <b>Disqualified:</b> ✗ 1000BASE-T Reason: Crosstalk fault          ✗ 100BASE-TX Reason: Crosstalk fault          ✗ Voice Over IP Reason: Crosstalk fault</p> <table border="1" style="width: 100%; border-collapse: collapse;"> <thead> <tr> <th>Date</th> <th>Time</th> <th>Length</th> <th>Version</th> <th>S/N</th> <th></th> </tr> </thead> <tbody> <tr> <td>2/26/2008</td> <td>12:30:39 AM</td> <td>35.9 ft</td> <td>V0.05.04</td> <td>00000005</td> <td></td> </tr> </tbody> </table>		Date	Time	Length	Version	S/N		2/26/2008	12:30:39 AM	35.9 ft	V0.05.04	00000005	
Date	Time	Length	Version	S/N									
2/26/2008	12:30:39 AM	35.9 ft	V0.05.04	00000005									
<p><b>Cable ID: Bedroom #3: 5</b> <span style="float: right;">Written notes:</span></p> <p><b>Qualified:</b> ✓ Wiremap Only; Telco  <b>Disqualified:</b> ✗ 1000BASE-T Reason: Excessive Length          ✗ 100BASE-TX Reason: Excessive Length          ✗ 10BASE-T Reason: Excessive Length          ✗ Voice Over IP Reason: Excessive Length</p> <table border="1" style="width: 100%; border-collapse: collapse;"> <thead> <tr> <th>Date</th> <th>Time</th> <th>Length</th> <th>Version</th> <th>S/N</th> <th></th> </tr> </thead> <tbody> <tr> <td>2/26/2008</td> <td>12:31:24 AM</td> <td>1053 ft</td> <td>V0.05.04</td> <td>00000005</td> <td></td> </tr> </tbody> </table>		Date	Time	Length	Version	S/N		2/26/2008	12:31:24 AM	1053 ft	V0.05.04	00000005	
Date	Time	Length	Version	S/N									
2/26/2008	12:31:24 AM	1053 ft	V0.05.04	00000005									

1 / 2



## N. RECORDS MANAGEMENT

### 80. Generic Cabling Management

80.1. The installer may provide written advice to the premises owner on the basic management and operation of the Generic Cabling system. Such advice may be in the form of standard information published by the supplier of the cabling hardware or a premises owner-specific document drawn up by the installer.

80.2. In particular, the user information should include:

80.2.1. a simple means of indicating the terminations within the Home Distributor that correspond with each TO and clearly explain the means of making and recording the necessary cross-connections; and

80.2.2. a clear explanation of how to disconnect house wiring from the network and test house wiring functions.

80.3. The overall aim is that information and installation records prepared by the installer should explain to the premises owner how the system is set up and have a reasonable chance of being able to make cross-connections when service “add, moves or changes” are needed.

80.4. Unless it is self-explanatory from inspection of the Home Distributor cabling and cross-connections, all Generic Cabling installations should be provided with clear installation instructions and facilities for recording the service connected to each jackpoint.

**Note:** The use of appropriate colour coding schemes and clear labelling of all components may be such as to obviate the need for a “paper record”, especially where the installation is small, and few services are connected. The aim is to ensure that the information available is such that an average premises owner or service person will not have undue difficulty in determining what service is connected to any TO.

80.5. Example of Test Instrument Produced Qualification Summary Report in the table below:

TO/HD DESIGNATION	Connected to	Service	Comments
1			
2			
3	Line 1 telephone		DECT base station
4	Colour Laser printer		
5	Ethernet switch Port 1	Home LAN	
6	DSL Modem	Broadband	
7			
8			
9	Ethernet switch Port 2	Home LAN	
10			
11			
12	Ethernet switch Port 3	TV	Smart TV
13	Ethernet switch Port 4	Media Server	Apple TV
14			
15			
16	Ethernet switch port 5	Gaming Console	
17			

18			
19			
20	Ethernet switch port 6	WiFi Access Point	In Lounge
21			
22	Ethernet switch port 7	WiFi Access Point	Upstairs
23			
24			

80.6. A typical example of a Generic Cable record is where every TO telecommunication cable is terminated on an RJ45 socket using the same designation within the Home Distributor.

## 81. Installation records

81.1. The installer should provide a basic record system relevant to the cabling and hardware installed in a format that the premises owner and subsequent service staff may annotate changes to the records (e.g., an outlet is used for another purpose).

81.2. The actual format of this record is left to the installer to agree with the owner of the premises. However, it is suggested that this be based on a floor plan of the premises showing TO locations and identification details for each TO.

**Note:** With a simple numbering system used for the TO's, these numbers should align with the termination numbers used at the Home Distributor end of the TO cables. Any record is then a simple case of stating what services are connected at each TO and showing any TO that is not in current use. This avoids the risk of premises owners thinking a TO is faulty when it is simply not connected at the TO.

81.3. An example of a simple cable record is shown above. Note that this record can become far more complicated if the TO and Home Distributor ends have different identification numbers or designations.

## 82. Compliance Statement Documentation

82.1. Following testing and any necessary remedial action, the installer should provide a written statement of compliance to the owner of the premises showing the extent of the testing carried out, the name and associated company of the person conducting those tests and the date on which the installation was compliant.

**Note:** It is recommended that this statement of compliance be housed within the Home Distributor cabinet.

## 83. Special Situations

83.1. Non-telecommunication systems such as gate entry systems must be connected on the premises owner's side of the network demarcation point. It is not permissible to divert and use the network provider's service lead-in cable between the network cable terminal on the road frontage and the network demarcation point at the building entry point, for this purpose

**Note:** Where a gate entry system is to be installed for a new building, especially if it has a long driveway, the recommended approach is to co-ordinate the service lead-in cable or pipe and gate entry cable installation with other building services work. This allows the several services concerned to share the cable trench, which is paid for by the property owner. The gate control installation contractor can then run the necessary control and communication wiring before the trench is closed.

83.2. Fixed wiring of CPE is limited to non-telecommunication systems such as security and alarm devices whose primary purpose would be defeated, if connected at any general purpose TO. Line grabbing CPE, such as security diallers, should be directly connected at the Home Distributor. Such connections may be via jumpers, patch cords or direct hard-wired connections.

83.3. Connection of alarm wiring should be terminated and connected in the Home Distributor. Such connections may be via jumpers, patch cords or direct hard-wire connections.

83.4. Where the building has a monitored fire alarm system that also uses a PSTN connection, the fire alarm system must be connected so that it will grab the line with a higher priority than security systems and similar.

---

## O. APPENDIX

### 84. Interim Steps for Legacy Wiring and DSL interference

84.1. Previous practice has been to add DSL signals to existing customer lines without modification to legacy wiring. This can place voice and DSL signals on to 2 and 3 wire legacy cable that was installed between TOs within the premises. Each TO is then fitted with a small plug-in filter to reduce DSL signals from reaching handsets connected to them.

84.2. The use of legacy wiring to carry DSL signals around a dwelling can result in high levels of radiated signals in the AM broadcast band. This shows up as high levels of wide band white noise (or hiss) on top of or even completely over riding AM Radio programmes being received at the premises. The interference is stronger when the DSL insertion point is close to a subscribers' home.

84.3. The upgrade to higher spec DSL products increases the interference and can be completely destructive of AM broadcast reception. Listener complaints demonstrate that this noise is commonly and incorrectly attributed to the broadcast station being off air or running at reduced power levels.

84.4. The methods described in the Testing for DSL leakage section of this document will significantly reduce the probability of interference. It is recommended that these be employed at the time a customer signs up for DSL. Home cabling is the responsibility of the homeowner, and if the homeowner continues to use legacy wiring, they must do so with the knowledge that their reception of AM broadcast stations may be affected.

84.5. To ensure best possible DSL performance, ensure functionality of alarm systems, and to limit interference it is recommended that a central DSL splitter be installed in the home distributor or at the demarcation point. CAT6 (or better) cable should then be used for DSL signals to the TO where the computer or modem will be connected. The use of plug in DSL filters is not recommended, however in the situation where they are to be used then they must be added to all TOs.

84.6. It is envisaged that existing residential and SDU premises will transition, through a series of stages, to a full Home Distributor over an extended period of time. The first stage may be as simple as installing a multi-point faceplate from which traditional PSTN and new TP CAT6 cables radiate out from and to which modems, network hubs and gateways connect to deliver service.

### 85. Testing for DSL leakage to AM radio

85.1. Where AM interference is suspected the following test should be carried out:

85.1.1. Turn off any other potential source of interference excluding the DSL modem which maybe an integral part of a computer.

85.1.2. Using a portable radio tune to a local AM station on a frequency close to 1100kHz. The best signal can usually be achieved outdoors away from overhead power lines. Once tuned, move the radio to a position within 2m of any part of the internal wiring.

85.1.3. With the line disconnected at the demarcation point, establish the level of noise normally present given the listening position. Without moving the radio, connect the line, ensure the DSL modem is logged on, and check if there is any increase in noise (hiss) on top of the station programme. If there is increased noise, there will need to be changes made to the premises wiring along the lines of the guidelines in the Appendix. The use of CAT6 cable (or better) will reduce the incidence of interference, but may not eliminate it, especially if an imbalance fault exists on the data side of the splitter.

- 85.1.4. Further information on compliance and regulation of radio interference is available on the below Radio Spectrum Management New Zealand (RSM) government website: <http://www.rsm.govt.nz>
- 85.1.5. If the interference issues cannot be resolved either by the homeowner or with the help of a technician, they should call 0508 RSM INFO for assistance.

## 86. New Home Schematic Diagrams

86.1. Based on the Best Practice Home Wiring and other illustrative cabling diagrams earlier in this document, the following diagrams cover all common RSP connection types and service offerings when installing telecommunication services into premises, such as:

- 86.1.1. Connection type
- 86.1.2. Modem/RGW locations
- 86.1.3. Broadband distribution scenarios
- 86.1.4. Voice distribution scenarios

## 87. Connection Type

### 87.1. Connection Type - Fibre

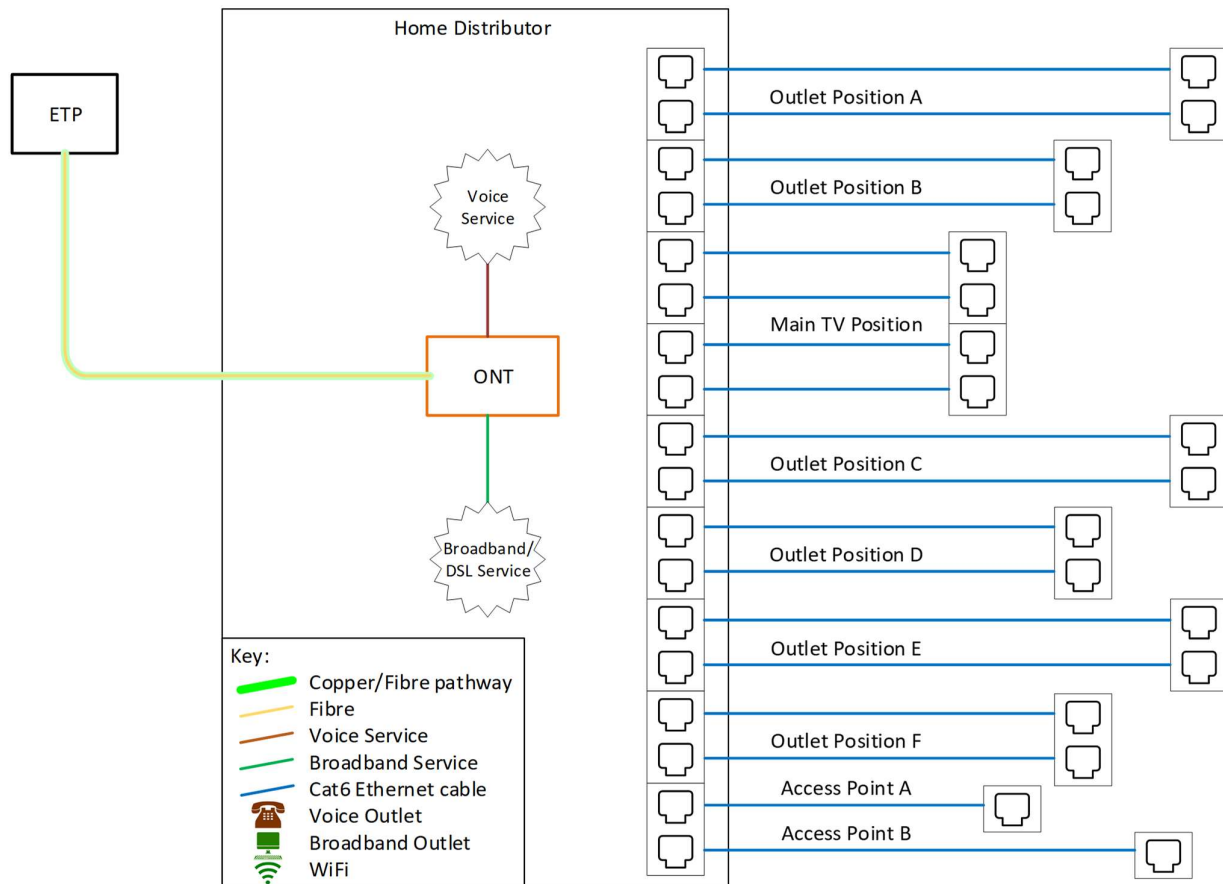

87.2. Connection Type – Fixed Wireless

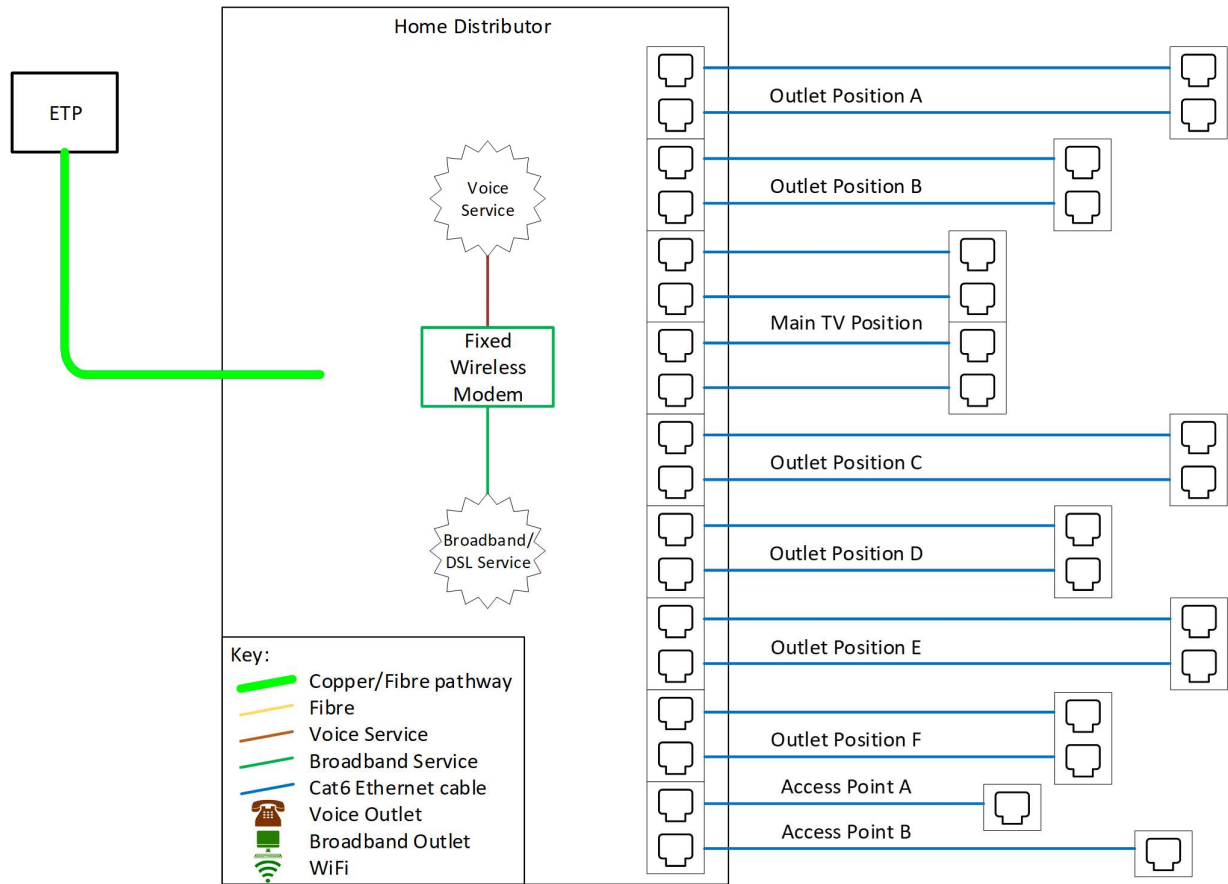

87.3. Connection Type – Copper

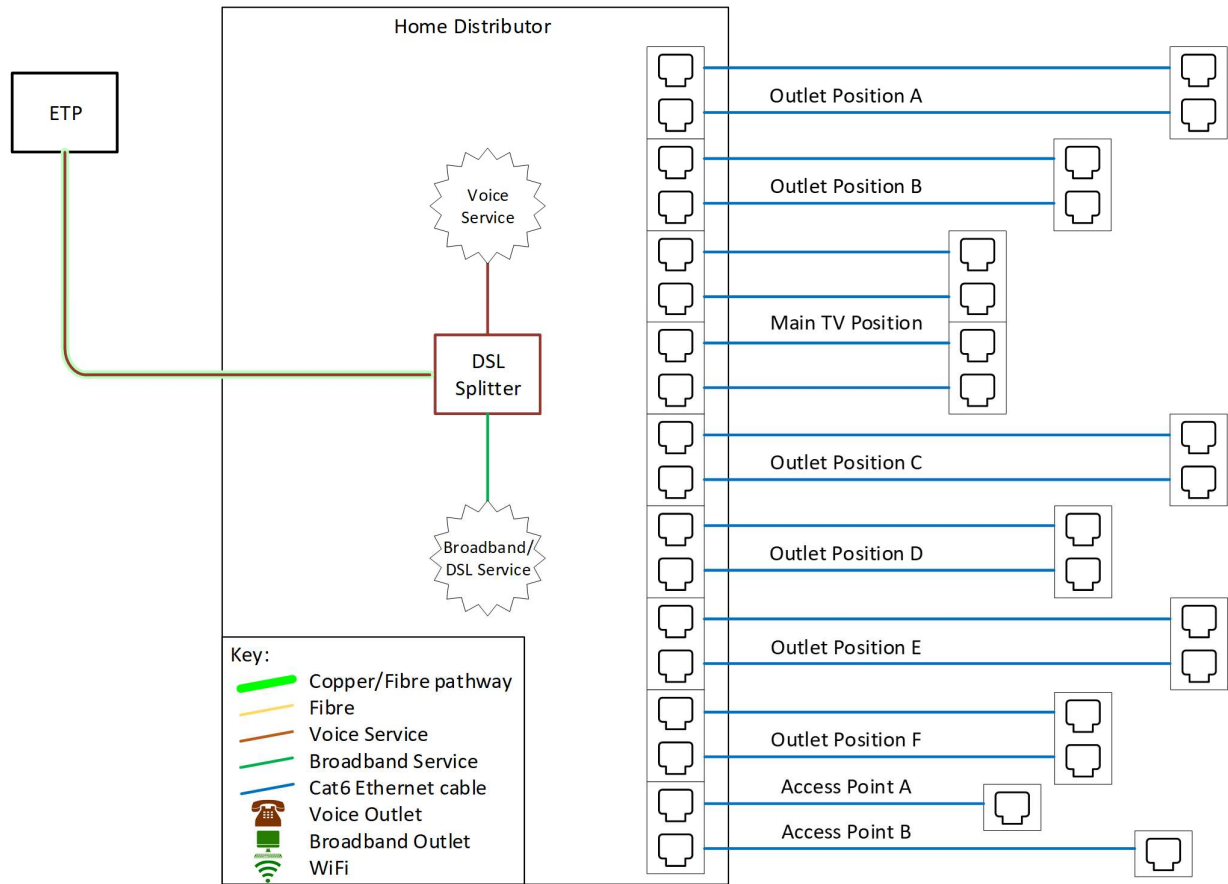



### 88. RGW/Modem Locations

88.1. In properties with star wiring, a RGW or Fixed Wireless Modem is most commonly placed within the Home Distribution Box, or near the primary TV.

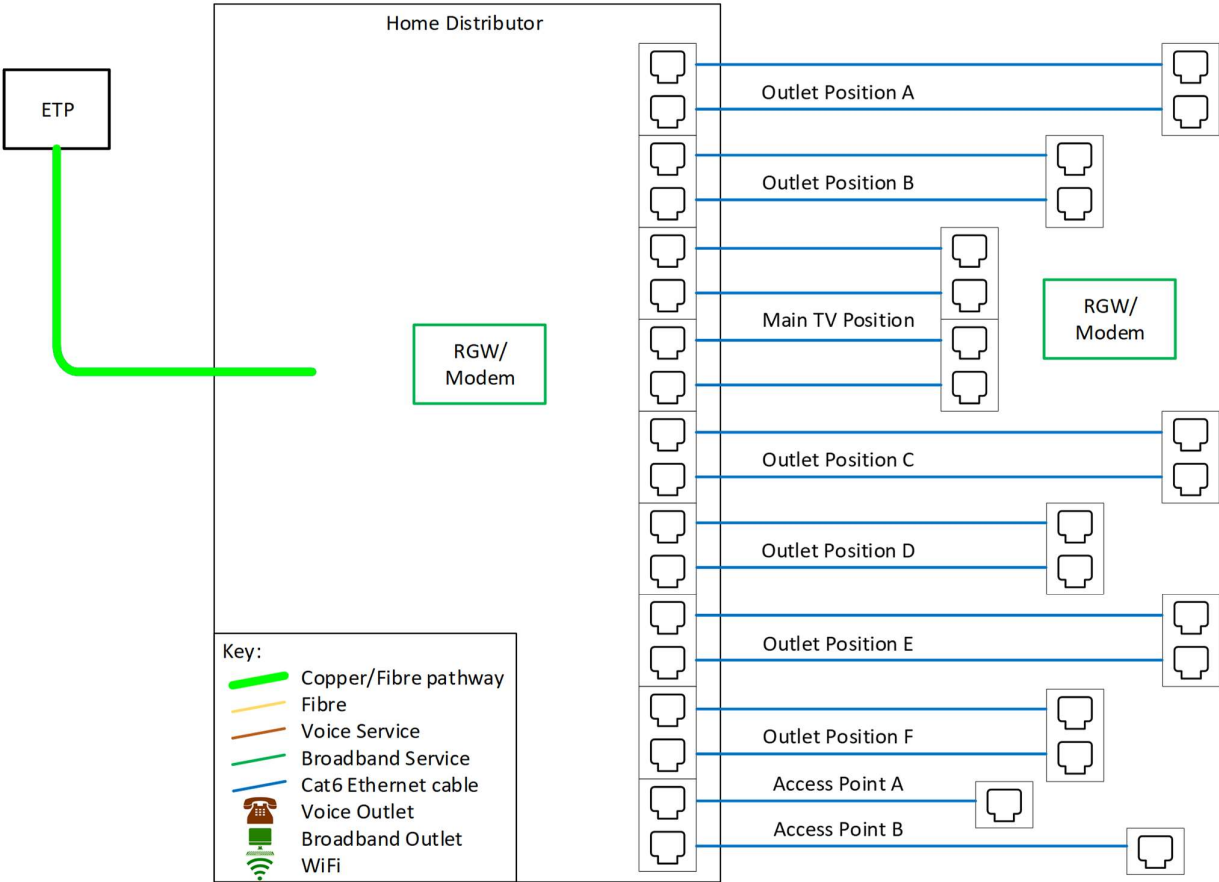

# 89. Broadband distribution scenarios

## 89.1. Modem/RGW in Home Distribution Box

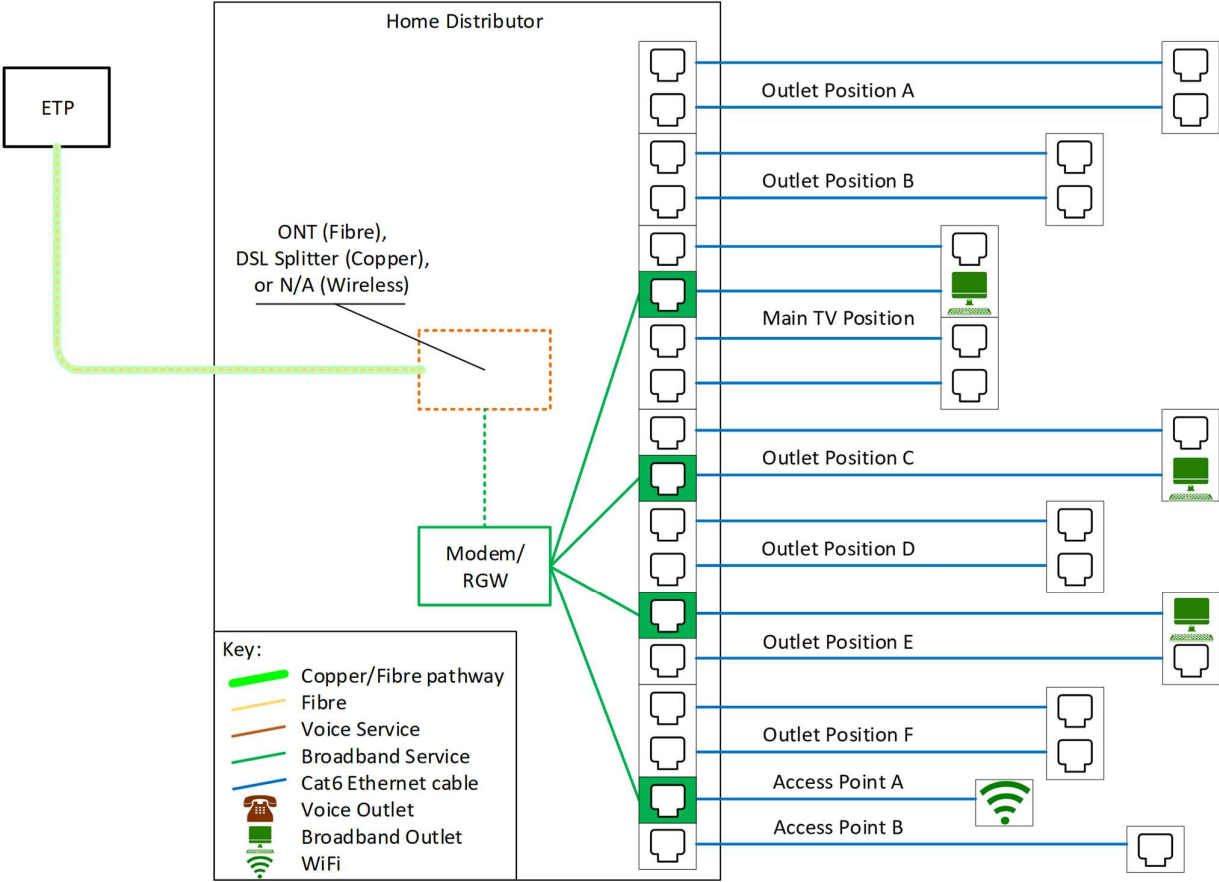

89.2. Modem/RGW in Home Distribution Box with Ethernet switch

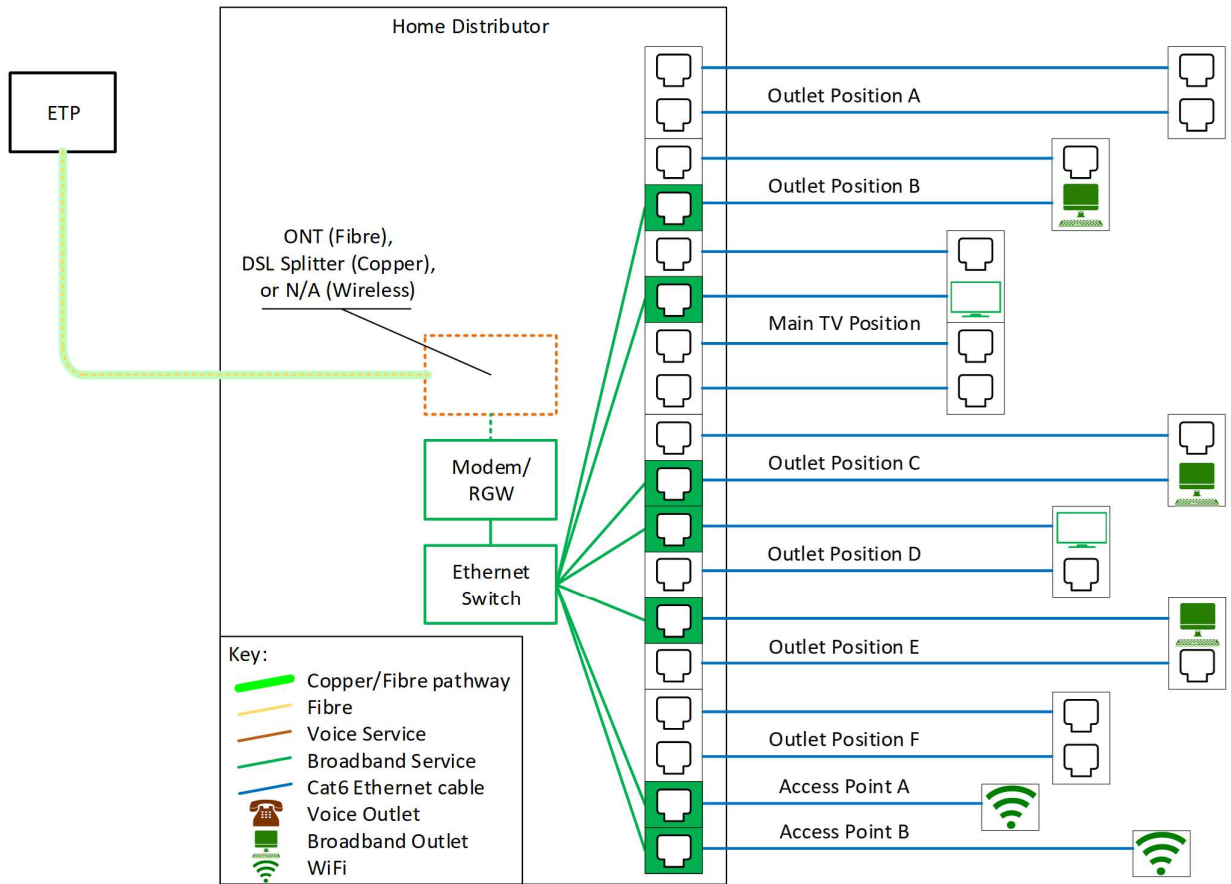

### 89.3. Modem/RGW by Main TV

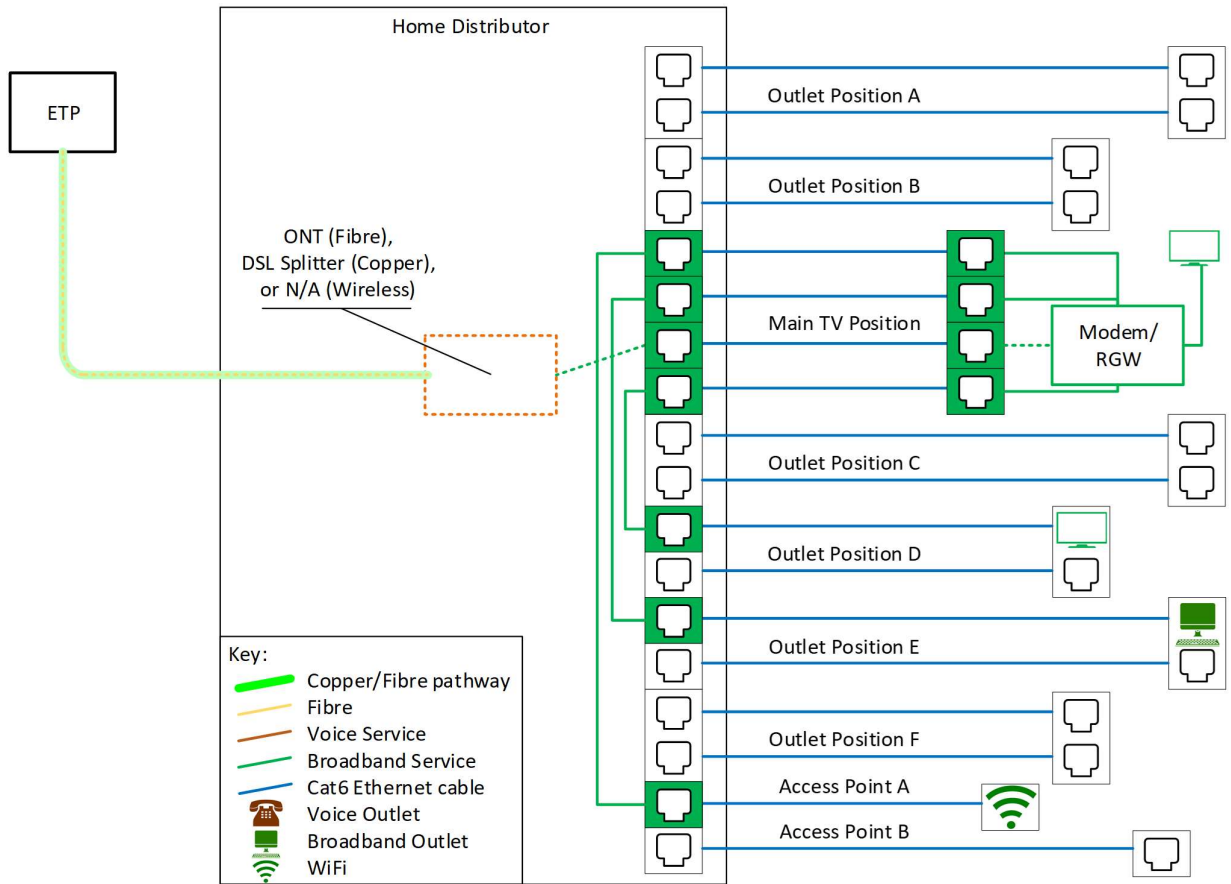

## 90. Voice distribution scenarios

90.1. Valid for all connection types (copper, fibre or fixed wireless) unless otherwise noted. A voice service can be supplied alone, or in conjunction with a broadband service.

90.2. Voice from Modem/RGW ATA Port

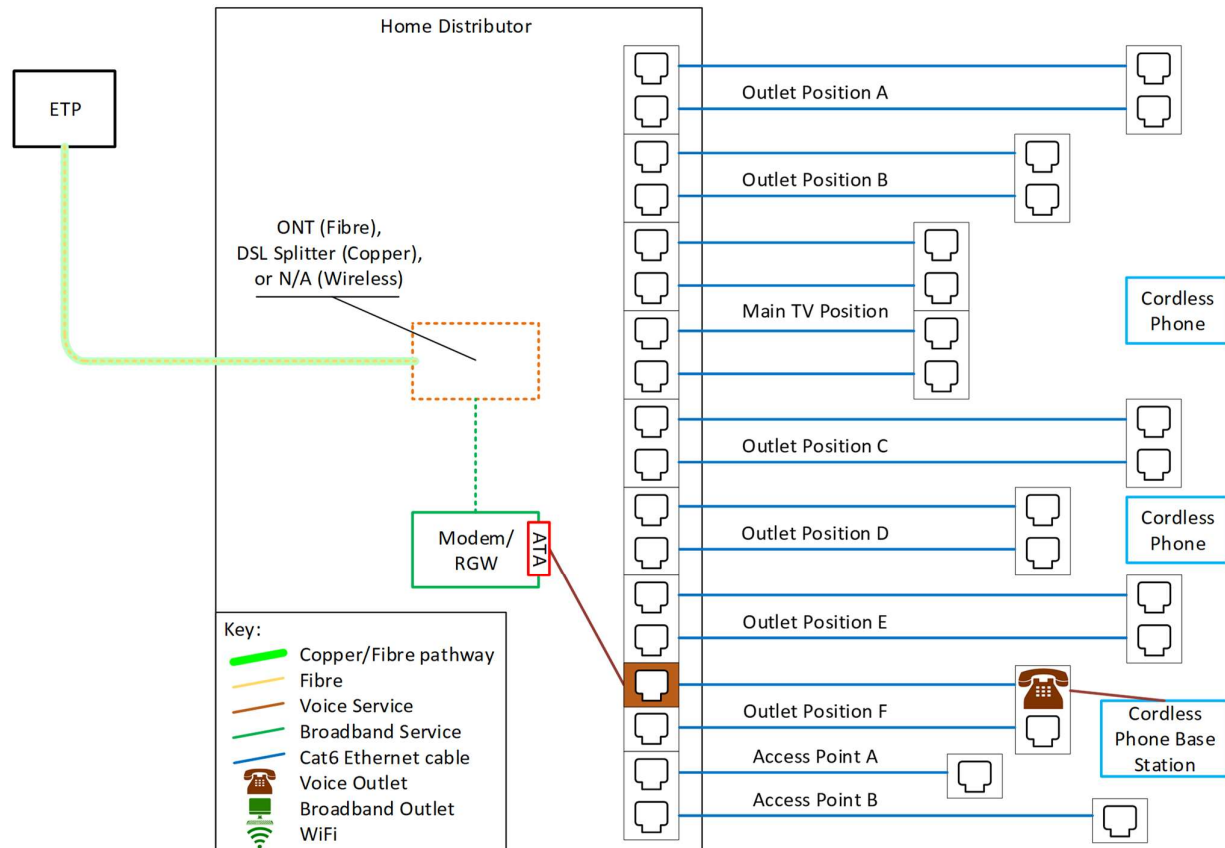

90.3. Voice from ONT ATA port (fibre connection only)

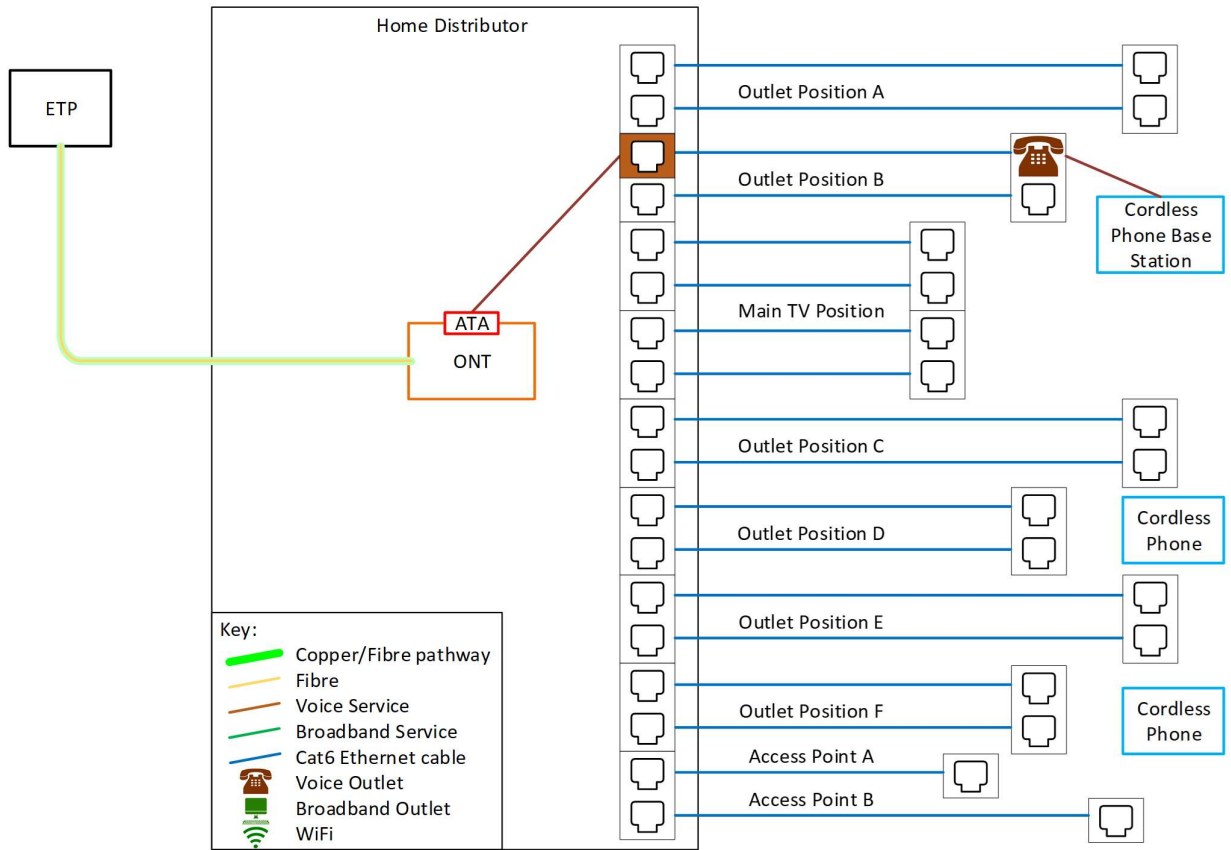

90.4. Voice distribution using telephone hub

